



ComCenter User's Guide

Release 040706

Table of Contents

Table of Contents

| | |
|---|----|
| Table of Contents..... | 2 |
| Precautions..... | 9 |
| Safety Information..... | 9 |
| Exposure to Radio Frequency Signals..... | 9 |
| Antenna Care..... | 9 |
| Unit Operation..... | 9 |
| Driving..... | 10 |
| Electronic Devices..... | 10 |
| Pacemakers..... | 10 |
| Other Medical Devices..... | 10 |
| Vehicles..... | 11 |
| Posted Facilities..... | 11 |
| Blasting Areas..... | 11 |
| Potentially Explosive Atmospheres..... | 11 |
| For Vehicles Equipped With Airbags..... | 11 |
| Important Notes for PBX System Users..... | 11 |
| ASE Limited Warranty..... | 12 |

| | |
|--|----|
| 1. Coverage and Duration..... | 12 |
| 2. Conditions Not Covered By This Warranty..... | 12 |
| 3. Obtaining Warranty Service..... | 14 |
| 4. General Provisions..... | 14 |
| 5. State Law and Other Jurisdiction Rights; Software Copyrights..... | 14 |
| 6. Contact..... | 15 |
| Part I: Setup..... | 16 |
| Installation..... | 16 |
| Power On Messages..... | 16 |
| Accessing ComCenter Settings..... | 17 |
| 1 Contrast..... | 18 |
| 2 Volume..... | 18 |
| 3 Identity..... | 18 |
| 4 Ontec..... | 18 |
| 5 Options..... | 19 |
| 6 Diagnostics..... | 19 |
| 7 Phone Book..... | 19 |
| # Exit..... | 20 |
| Part II: Calling..... | 21 |
| Making a Call..... | 21 |
| What You Will Hear..... | 21 |

| | |
|---|----|
| Calling With SmartDial..... | 21 |
| 911 Emergency Calls With SmartDial..... | 21 |
| Calling Without SmartDial..... | 22 |
| 911 Emergency Calls Without SmartDial..... | 22 |
| Answering a Call..... | 22 |
| Making a Data Call..... | 23 |
| Hardware Connection..... | 23 |
| Software Connection..... | 23 |
| Appendix I: Iridium Handset..... | 24 |
| What Is a SIM Card?..... | 24 |
| Using additional SIM Card (Other than SIM card already in Iridium satellite phone)..... | 25 |
| Powering Up the ComCenter..... | 26 |
| Power-On Messages..... | 27 |
| Placing a Call..... | 28 |
| What's My SIM Card Phone Number?..... | 32 |
| Receiving a Call..... | 33 |
| Using In-Call Features..... | 36 |
| Muting a Call..... | 36 |
| Using the Menus..... | 37 |
| Using the Options Menu..... | 38 |
| Customize the Options Menu..... | 40 |

| | |
|---|----|
| Using The In-Call Menu..... | 43 |
| Entering the In-Call Menu..... | 43 |
| Managing the Phone Book..... | 44 |
| What’s on the Phone Book Menu?..... | 47 |
| Organizing Your Phone Book..... | 48 |
| Storing Names and Numbers..... | 50 |
| Entering Names..... | 52 |
| Locating Entries..... | 57 |
| Find an Entry by Location..... | 58 |
| Calling, Modifying, or Erasing an Entry..... | 59 |
| Checking Phone Book Capacity..... | 61 |
| Preventing Access to the Phone Book..... | 62 |
| Restricting Phone Use..... | 64 |
| Add an Entry..... | 66 |
| Erase an Entry..... | 67 |
| Edit an Entry..... | 68 |
| View Your Fixed Dialing List..... | 69 |
| Viewing the Last Ten Numbers Dialed..... | 70 |
| Viewing and Modifying Your Phone Numbers..... | 71 |
| One-Touch Dialing..... | 73 |
| Using Calling Features..... | 75 |

| | |
|--|-----|
| What's on the Call Related Features Menu?..... | 77 |
| Forward Calls When Unavailable..... | 78 |
| Forward All Your Calls..... | 80 |
| Detailed Call Forwarding..... | 81 |
| Cancel All Forwarding..... | 83 |
| Showing Signal Strength..... | 84 |
| Deactivating Pending Call Drop Signal..... | 86 |
| Restricting Calls with Call Barring..... | 87 |
| Change Bar Password..... | 89 |
| Using Message Services..... | 90 |
| What's on the Messages menu?..... | 92 |
| Checking Your Voicemail..... | 93 |
| Storing Your Voicemail Number..... | 93 |
| Managing Your Messages (This is only accessible when using the Iridium handset)..... | 94 |
| Accessing Messages..... | 96 |
| Go to the Next Message..... | 99 |
| Managing Outgoing Messages (SMS-MO)(only accessible with Iridium handset)..... | 100 |
| Create a New Message (SMS-MO)..... | 101 |
| Edit a Message (SMS-MO)..... | 102 |
| Send a Message (SMS-MO)..... | 103 |
| Store a Message (SMS-MO)..... | 105 |

| | |
|---|-----|
| Enter Service Center Number (SMS-MO)..... | 109 |
| Set Expiry period (SMS-MO)..... | 111 |
| Customizing Phone Features..... | 113 |
| What's on the Phone Setup Menu?..... | 115 |
| Adjusting the Ringer Volume..... | 116 |
| Setting the Ringer Tone..... | 117 |
| Setting the Keypad Tones..... | 118 |
| Locking and Unlocking Your Phone..... | 119 |
| Change the Unlock Code..... | 121 |
| Protecting the SIM Card..... | 123 |
| Managing Other Security Settings..... | 127 |
| Activating Extended Menus..... | 130 |
| Selecting the Display Language..... | 131 |
| Review the Phone's Settings..... | 132 |
| Accessing the Network..... | 135 |
| What's on the Network Selection Menu?..... | 136 |
| Registering With the Satellite Network..... | 137 |
| Timing Your Calls..... | 138 |
| What's on the Call Meters Menu?..... | 140 |
| Showing Call Timers..... | 141 |
| Setting Audible Call Timers..... | 143 |

| | |
|--|-----|
| Showing the In-Call Timer..... | 146 |
| Showing the Lifetime Timer..... | 146 |
| Customizing the Menu System..... | 148 |
| Personalizing the Options Menu..... | 148 |
| Personalizing the Quick Access Menu..... | 151 |
| Menu Quick Reference..... | 152 |
| Phone Book Menu..... | 153 |
| Call Related Features Menu..... | 154 |
| Messages Menu..... | 155 |
| Phone Setup Menu..... | 156 |
| Network Selection Menu..... | 157 |
| Call Meters Menu..... | 158 |
| Troubleshooting..... | 159 |
| Appendix II: Basic AT Command Set..... | 163 |

Precautions

Please read and understand this User's Manual before installing your ComCenter. Careless or incorrect installation can degrade performance, damage both new and existing equipment, and incur unexpected network airtime charges.

Safety Information

Exposure to Radio Frequency Signals

Your Iridium-designed satellite unit is a low power radio transmitter and receiver. When it is ON, it receives and sends out radio frequency (RF) signals.

International agencies have set standards and recommendations for the protection of public exposure to RF electromagnetic energy:

- International Commission on Non-Ionizing Radiation Protection (ICNIRP) 1996
- Verband Deutscher Elektrotechniker (VDE) DIN-0848
- United States Federal Commission, Radio Frequency Exposure Guidelines (1996)
- National Radiological Protection Board of the United Kingdom, GS 11, 1988
- American National Standards Institute (ANSI) IEEE C95, 1-1992
- National Council on Radiation Protection and Measurements (NCRP) Report 86
- Department of Health and Welfare Canada, Safety Code 6

These standards are based on extensive scientific review. For example, over 120 scientists, engineers, and physicians from universities, government health agencies, and industry reviewed the available body of research to develop the updated ANSI standard.

The design of your phone complies with these standards when used as described under "Unit Operation."

Antenna Care

Use only the supplied or an approved replacement antenna. Unauthorized antennas, modifications, or attachments could damage the phone and may violate local agency regulations.

Unit Operation

Do not operate the unit when a person is within 4 inches (10 centimeters) of the antenna.

A person or object within 4 inches (10 centimeters) of the antenna could impair call quality and may cause the unit to operate at a higher power level than necessary and expose that person to RF energy in excess of that established by the FCC RF Exposure Guidelines.

Driving

Check the laws and regulations on the use of wireless telephones in the areas where you drive. Always obey them. Observe the following guidelines when using your phone while driving:

- Give full attention to driving—driving safely is your first responsibility.
- Use hands-free phone operation, if available.
- Pull off the road and park before making or answering a call if driving conditions so require.

Electronic Devices

Most modern electronic equipment is shielded from RF signals. However, certain equipment may not be shielded against RF signals from your Iridium-designed satellite unit.

Pacemakers

The Health Industry Manufacturers Association recommends that a minimum separation of 6 inches be maintained between a wireless phone's antenna and a pacemaker to avoid potential interference with the pacemaker. These recommendations are consistent with the independent research by and recommendations of Wireless Technology Research.

Persons with pacemakers:

- Should ALWAYS keep the Iridium-designed satellite unit more than six inches from their pacemaker when the unit is turned ON.
- Should turn the unit OFF immediately if you have any reason to suspect that interference is taking place.

Other Medical Devices

If you use any other personal medical device, consult the manufacturer of your device to determine if it is adequately shielded from external RF energy. Your physician may be able to assist you in obtaining this information.

Turn your unit OFF in health care facilities when any regulations posted in these areas instruct you to do so. Hospitals or health care facilities may be using equipment that could be sensitive to external RF energy.

Vehicles

RF signals may affect improperly installed or inadequately shielded electronic systems in motor vehicles. Check with the manufacturer or its representative regarding your vehicle. You should also consult the manufacturer of any equipment that has been added to your vehicle.

Posted Facilities

Turn your unit OFF in any facilities where posted notices so require.

Blasting Areas

To avoid interfering with blasting operations, turn your unit OFF when in a "blasting area" or in areas posted "Turn off two-way radio." Obey all signs and instructions.

Potentially Explosive Atmospheres

Turn your unit OFF and disconnect the power supply when you are in any area with a potentially explosive atmosphere. Obey all signs and instructions. Sparks from your battery or power source in such areas could cause an explosion or fire resulting in bodily injury or even death.

Areas with a potentially explosive atmosphere are not always clearly marked. They include, but are not limited to: fueling areas such as gasoline stations; below deck on boats; fuel or chemical transfer or storage facilities; areas where fuel odors are present (for example, if a gas/propane leak occurs in a car or home); areas where the air contains chemicals or particles, such as grain, dust, or metal powders; and any other area where you normally would be advised to turn off your vehicle engine.

For Vehicles Equipped With Airbags

An air bag inflates with great force. Do NOT place objects, including both installed or portable wireless equipment, in the area over the air bag or in the air bag deployment area. If in-vehicle wireless equipment is improperly installed and the air bag inflates, serious injury could result.

Important Notes for PBX System Users

If using the ComCenter with a PBX system, three precautions must be followed to prevent damage to your unit.

1. The ComCenter functions as a central office (i.e., the ComCenter emulates the wall jack). Do not connect the ComCenter as an extension.
2. When connecting the ComCenter to the PBX, it need to be connected as analog only. Connecting

the ComCenter as other than analog may result in damage to the RJ11 interface.

3. Do not try to ring the ComCenter as if it were an extension on the PBX system. The ComCenter has a built-in ringer so that when a call is received, the unit will ring to alarm that a call is coming in. Trying to ring the ComCenter unit from the PBX system could result in damage to the RJ11 interface.

ASE Limited Warranty

1. Coverage and Duration

Applied Satellite Engineering, Inc. (ASE) warrants that its new satellite subscriber radiotelephone products and accessories (the "Product") shall be free from defects in materials and workmanship for a period of twelve (12) months from the date such Product is delivered to the first end-user purchaser or first lessee (the "Purchaser"), or the date such Products are first placed into satellite subscriber service, whichever occurs earliest. ASE, at its option, shall at no charge to Purchaser, either repair or replace the Product, or refund the purchase price of a Product that does not conform to this warranty, provided the Product is returned in accordance with the instructions set out below and within the warranty period. These remedies are Purchaser's exclusive remedies under this warranty. Repair may include the replacement of parts or boards with functionally equivalent reconditioned or new parts or boards. A Product that has been repaired or replaced is warranted for the balance of the original warranty period. A Product for which a replacement has been provided shall become ASE's property.

This warranty is made by ASE to the Purchaser of the Products only, and it is not assignable or transferable by the Purchaser. This is ASE's sole and complete warranty for the Products. ASE assumes no obligation or liability for additions or modifications to this warranty unless made in writing and signed by an officer of ASE. ASE does not warrant any installation, maintenance, or service of the Products not performed by ASE.

This product is covered by a U.S.A. warranty. If the Product has been sold outside of the U.S.A., ASE will honor the U.S.A. warranty terms and conditions only. Outside of the U.S.A., any different warranty terms, liabilities, and/or legal requirements of the country in which the Product is sold are specifically disclaimed by ASE.

2. Conditions Not Covered By This Warranty

- a. Products that are integrated, installed, maintained, or serviced in any manner other than in accordance with the ASE user documentation furnished with or applicable to the Product.
- b. Product damage caused by the use of ancillary equipment not furnished by ASE, including

accessories and peripherals.

c. Problems where the Product is used in a combination with ancillary equipment not furnished by ASE and it is determined by ASE there is no fault with the Product.

d. Ancillary equipment not furnished by ASE that is attached to or used in connection with the Products is not the responsibility of ASE, and all such equipment is expressly excluded from this warranty. Furthermore, ASE does not warrant the integrated operation of the combination of the Products with any ancillary equipment not furnished by ASE.

e. Defects or damage resulting from: use of the Product in any manner not normal or customary; misuse, accident, or neglect, including but not limited to dropping the Product onto hard surfaces, immersion in or exposure to water, rain or extreme humidity, immersion in or exposure to sand, dirt, or other particulates, exposure to extreme heat, spills of food or liquid; improper testing, operation, maintenance, installation, adjustment; or any alteration or modification of any kind.

f. Batteries manufactured by ASE and sold with Products whose capacity exceeds 80% of rated capacity are not covered. Batteries whose capacity falls below 80% of rated capacity, or that develop leakage, shall be considered non-conforming. This warranty is voided for batteries if: i) such batteries are charged by other than the ASE-approved battery charger specified for charging such batteries; ii) any seals on such batteries are broken or show evidence of tampering; iii) such batteries are used in equipment other than the Product for which they are specified; or iv) such batteries are charged and stored at temperatures greater than 60 degrees Celsius.

g. Breakage or damage to antennas, or scratches or other damage to plastic surfaces or other externally exposed parts caused by Purchaser's use.

h. Products disassembled or repaired in such a manner as to adversely affect performance or prevent adequate inspection and testing to verify any warranty claim.

i. Products on which serial numbers or date tags have been removed, altered, or obliterated.

j. Coil cords that are stretched or on which the modular tab is broken; leather cases, which are covered under separate manufacturer's warranties.

k. Products rented on a month-to-month basis.

l. Normal wear and tear.

3. Obtaining Warranty Service

For warranty questions, repairs, or for the return of Product, please call your Service Provider or Point-of-Sale, not ASE. Equipment needing service should be returned to your Service Provider or Point-of-Sale, not ASE. SERVICE WORK PERFORMED BY SERVICE CENTERS NOT AUTHORIZED BY ASE TO PERFORM SUCH WORK WILL VOID THIS WARRANTY.

All products shipped to ASE's authorized Warranty Service Center must be shipped with freight and insurance prepaid. Purchaser must include with the Product a bill of sale, a lease, or some other comparable proof of purchase, the name and location of the installation facility, if any, and most importantly, the Purchaser's name, address, and telephone number and a written description of the problem. Product that is repaired or replaced under this warranty shall be returned to Purchaser at ASE's expense for the freight and insurance, and at Purchaser's expense for any applicable duties or other charges. If additional information is needed, please contact ASE at the address and phone number listed in Paragraph 6 below.

4. General Provisions

THIS WARRANTY IS GIVEN IN LIEU OF ALL OTHER WARRANTIES EXPRESS OR IMPLIED, INCLUDING BUT NOT LIMITED TO THE IMPLIED WARRANTIES OF MERCHANTABILITY AND FITNESS FOR A PARTICULAR PURPOSE. FURTHER, THIS WARRANTY COVERS THE PRODUCTS ONLY, AND NO WARRANTY IS MADE AS TO COVERAGE, AVAILABILITY, OR GRADE OF SERVICE PROVIDED BY ASE SEPARATELY FOR ASE SATELLITE SERVICES. IN NO EVENT SHALL ASE BE LIABLE FOR DAMAGES IN EXCESS OF THE PURCHASE PRICE OF THE PRODUCT IN QUESTION, OR FOR ANY LOSS OF USE, LOSS OF TIME, INCONVENIENCE, COMMERCIAL LOSS, LOST PROFITS OR SAVINGS OR OTHER INCIDENTAL, SPECIAL, OR CONSEQUENTIAL DAMAGES ARISING OUT OF THE USE OR INABILITY TO USE SUCH PRODUCT, TO THE FULL EXTENT SUCH MAY BE DISCLAIMED BY LAW.

5. State Law and Other Jurisdiction Rights; Software Copyrights

Some states and other jurisdictions do not allow the exclusion or limitation of incidental or consequential damages, or limitation on how long an implied warranty lasts, so the above limitations or exclusions may not apply to Purchaser.

This warranty gives Purchaser specific legal rights, and Purchaser may also have other rights that vary from jurisdiction to jurisdiction.

Laws in the United States and other countries preserve for ASE certain exclusive rights for copyrighted

Product software such as the exclusive rights to reproduce in copies and distribute copies of such Product software. Product software may be copied into, used in, and redistributed with only the Product associated with such Product software. No other use, including without limitation disassembly, of such Product software or exercise of exclusive rights in such Product software is permitted.

6. Contact

For additional information about this Product warranty, please contact your Service Provider or Point-of-Sale. For additional information about ASE products and services, please contact ASE as follows:

Telephone: 480.443.1424

Facsimile: 480.452.0971

E-mail: info@ase-corp.com

Mail: Applied Satellite Engineering, Inc.

15875 N. Greenway-Hayden Loop, Suite 113

Scottsdale, AZ 85260 USA

Part I: Setup

Installation

Refer to the instructions provided with your Iridium antenna to ensure proper placement. Clear line of sight to the Iridium satellites is fundamental to satellite phone connectivity. Be sure the antenna will reach your desired installation point inside your building. The ComCenter must be kept in a dry, climate-controlled space.

After the antenna is installed, simply connect the ComCenter to the antenna, attach an analog handset to the ComCenter, and connect the power source to the ComCenter. Your unit automatically starts when power is applied.

Power On Messages

Before turning on your ComCenter, be sure that you have attached the antenna and all peripherals you wish to use—telephone handset, modem, etc. Connecting all peripherals first will ensure that the ComCenter recognizes them during boot-up.

The ComCenter does not have a power switch. Instead, simply plug or unplug the power adapter to turn the unit on or off.

We recommend you watch the ComCenter screen closely during boot-up. The messages displayed will help you troubleshoot your system should it not provide a clear signal (or any signal at all). Following are the boot messages, in sequence:

1. REGISTERING . . .

This step usually flashes by in less than a second. The ComCenter is performing a self-check.

Troubleshooting: If your system fails during this step, contact your reseller. Your ComCenter may have a hardware problem.

2. SEARCHING . . .

This step can take 20 to 30 seconds. The ComCenter is locating and connecting to the Iridium satellites.

Troubleshooting: If your system fails during this step, check your antenna. Your ComCenter cannot find the Iridium satellites at all.

3. FOUND HOME NETWORK

This step can take 10 to 20 seconds. The ComCenter is communicating with the Iridium network to

establish its availability to send and receive calls.

Troubleshooting: If your system fails during this step, contact your reseller. Your ComCenter may have a software problem.

4. REGISTERED ...
ACQUIRING SYS INFO

This step can take another 10 to 20 seconds. The ComCenter has established a network connection to Iridium and is downloading and synchronizing settings like time and date.

Troubleshooting: If your system fails during this step, contact your reseller. Your Iridium service may have been interrupted.

5. If the boot process is successful, the ready screen will appear.

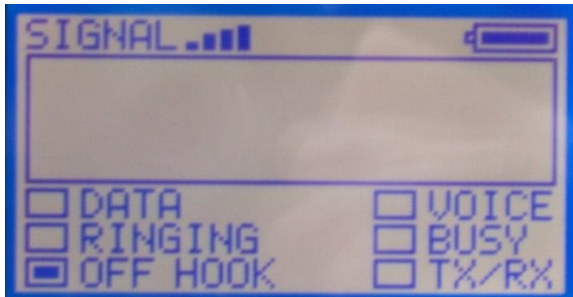

Lift your handset and you should hear dialtone. Your ComCenter is in Ready Mode and you may now make and receive calls.

Accessing ComCenter Settings

In Ready Mode, take the handset off hook and press * to access the Settings menu. The following options are available:

| | |
|------------|---------------|
| 1 CONTRAST | 4 ONTEC |
| 2 VOLUME | 5 OPTIONS |
| 3 IDENTITY | 6 DIAGNOSTICS |
| # EXIT | 7 PHONE BOOK |

If you enter the Settings menu and do not press a key for 45 seconds, the ComCenter will automatically return to Ready Mode. (The phone line will still be open but may have gone to fast busy signal. Hang up the

receiver on the attached phone.) Read on for detailed descriptions of the Settings options.

1 Contrast

The Contrast option controls the ComCenter LED display. Press 1 to make the screen lighter; press 2 to make the screen darker. The range is 20 steps from darkest to lightest. The ComCenter is shipped by default at the midpoint of brightness. Your customized contrast settings are retained after reboots. There is no graphical display of the LED setting other than the appearance of the display screen itself.

Press # to return to the Settings menu.

2 Volume

The Volume option controls the audio level sent to the handset. Press 1 to make the sound louder; press 2 to make the sound softer. The range is four steps from softest to loudest. By default the ComCenter is at the midpoint of volume. A graphical display bar shows the current level.

Press # to return to the Settings menu.

3 Identity

The Identity option provides important information about your ComCenter. You may need this information for technical support or Iridium network issues. Three lines appear in the display:

The first line is firmware. This number indicates the current software in the ComCenter.

The second line is SN. This number identifies your ComCenter unit by ASE serial number.

The third line is IMEI. This number identifies your ComCenter network connection to Iridium.

Press # to return to the Settings menu (note this command is not displayed on the screen).

4 Ontec

The Ontec option is only for subscribers to Ontec Web Services. (Ontec Web Services are provided by subscription and must be purchased with your ComCenter. Ask your service provider for more details.) As soon as you press 4 for this option, you will see this message:

RUDICS CALL IN PROGRESS

This message indicates the ComCenter is attempting to connect to Ontec Web services. If you are not an Ontec subscriber and you choose this option, you must wait until the connection times out and returns you to the main Settings menu. This may take from 10 to 60 seconds. If you are too impatient, you can reboot

your ComCenter.

Press # to return to the Settings menu.

5 Options

The Options screen contains three pages of options.

From the first page:

Press 2 to turn crew log on or off.

Press 3 to toggle SmartDial on or off. (We strongly recommend you leave SmartDial on.)

Press 4 for the next screen.

From the second page:

Press 1 to toggle USA 911 dialing on or off. This setting partially overrides SmartDial recognition of country codes and allows United States callers to simply type 911 to access the emergency system. (If this setting is off, then calls starting with “91” are recognized as dialing the country code for India.)

Press 4 for the next screen.

From the third page:

Press 1 to clear the call log.

Press # to return to the previous screen.

Press # repeatedly to return to the Settings menu.

6 Diagnostics

The Diagnostics option helps ASE technical support understand what your ComCenter is doing.

Press # to return to the Settings menu.

7 Phone Book

The Phone Book option lists the telephone numbers stored in your ComCenter. The ComCenter can store 200 phone numbers, but you must add and delete numbers using a separate Iridium handset. (See the appendix for more details about this equipment.) If you have numbers in your phone book, you can page through them using the 1 and 2 keys.

Press # to return to the Settings menu.

Exit

Press # to return to Ready Mode.

Part II: Calling

Making a Call

What You Will Hear

The first thing you hear is dialtone. You may notice that the tone is a slightly higher pitch than the dialtone you are used to. While you are connecting, you will not hear a ring, but instead a short beep. If the call fails during connection, you will hear a rapid beeping—try your call again. If the line you are calling is busy, you will hear a normal busy signal.

Calling With SmartDial

SmartDial is special technology to remove the hassles of international dialing. Instead of trying to remember to dial operators, then sequences of numbers, the ComCenter's SmartDial function enables direct dialing to any country. Only three steps are required:

1. Lift the phone to go off-hook. You will see the prompt **ENTER PHONE NUMBER:**.
2. Enter the country code. (For example, the United States is 1, Great Britain is 44.) As soon as you enter the country code, you will see that country name at the bottom of the LED.
3. Enter the area code and number. The ComCenter automatically starts dialing the connection after the last digit.

SmartDial knows how many digits to expect based on the country code. (In the United States it is ten digits.) Now, whenever you see an international number that you want to dial, you can enter it verbatim into the ComCenter and easily reach your party.

911 Emergency Calls With SmartDial

With SmartDial turned on and USA 911 turned on in the Options settings (see above), dialing **911** will call emergency services. Because 91 is the country code for India, the ComCenter must be programmed to ignore the country code if 911 is dialed. For United States users, this is the best setting, even if calls to India are frequent (it is safer to use SmartDial Override and keep 911 functionality).

Warning: If you turn off USA 911 in the Options settings, all 911 emergency calls will be ignored. To reiterate: with USA 911 turned off, you cannot dial 911 in any way. All calls starting with 91 will be recognized as calls to India. Even entering 1 for the United States country code will not allow 911 to be dialed.

Calling Without SmartDial

Without SmartDial, you must follow a different dialing sequence:

1. Lift the receiver to go off-hook.
2. Enter 0 0 (zero zero). You will see the prompt `PRESS # TO SEND` at the bottom of the screen indicating that you are not in SmartDial mode.
3. Enter the country code.
4. Enter the area code and telephone number.
5. Enter # to connect.

The ComCenter does not recognize country codes or number string lengths with SmartDial off. You must enter all digits correctly and press # to initiate the call—the ComCenter does not automatically dial with SmartDial off.

Temporarily Overriding SmartDial

If you are using SmartDial and want to override it temporarily, simply dial 0 and your ComCenter will go to manual mode. Again, you will see the prompt `PRESS # TO SEND` at the bottom of the screen indicating that you are not in SmartDial. At this point, follow the instructions above for dialing without SmartDial.

911 Emergency Calls Without SmartDial

With SmartDial off, dialing United States 911 is not disabled, but you must still enter # to send the number and make the connection. To clarify: without SmartDial, you must enter **911#** to reach emergency services.

Answering a Call

The ComCenter has a built-in ringer to alert you to an incoming call. Your handset probably also has a ringer, so you may wish to turn it off. (The ComCenter cannot be silenced.) An exception could be if you are using a cordless handset away from your ComCenter and cannot hear distant ringing.

When a call comes in, simply use your handset like you normally would. Speak in a regular tone of voice. You should find most of your calls are at least as clear as a cellular phone call and often as clear as a standard wire-line phone call. The only minor difference in receiving a ComCenter call is this: when the caller at the other end disconnects, if you continue to hold your receiver off-hook you will get a dial tone. Be sure to hang up your handset normally.

Making a Data Call

The serial port on the ComCenter provides data connectivity, using the ComCenter as a modem. Although software applications are similar at the hardware command level, the precise operation of individual packages is beyond the scope of this manual. Following are instructions for connecting your computer to the ComCenter.

Hardware Connection

The ComCenter provides a standard 9-pin male serial port. If your computer has a 9-pin or 25-pin serial port available, you should attach to the ComCenter data port with a standard DB9 cable. Connect the cable to the ComCenter first, then to your computer. You likely will have to reboot your computer for the operating system to correctly recognize and initialize the serial port and communicate with the ComCenter.

Many current computers (especially laptops) no longer provide 9-pin serial ports and instead offer USB ports. (This makes sense because USB stands for Universal Serial Bus and is intended to be the next generation of the old serial connections.) Although the ComCenter does not have USB ports built in, you can use a USB-to-DB9 adapter cable. Connect the cable to the ComCenter first, then plug the USB connector in to your computer. Your operating system should now be able to address the ComCenter.

Software Connection

The ComCenter is configured to recognize the standard Hayes AT modem command set. The AT compatibility means virtually any terminal software program you may wish to use will be able to dial out and negotiate a data session.

To test your ComCenter in data mode using Windows XP, start the HyperTerminal program. Then enter the command “ATDTxxxxxx” where xxxxxx is a known phone number to a computer or fax machine. Hit the Enter key and watch the screen for response messages from the modem, such as “DIALING” or “CONNECT.”

See Appendix II for a reference to the basic AT commands.

Appendix I: Iridium Handset

Read this section to learn how to get up and running with your new Iridium designed satellite unit. Many features listed under this section are only available with use of an optional Iridium handset.

What You Will Learn

- what is a SIM card?
- inserting your SIM card
- turning the power on and off
- placing and receiving calls
- using hands-free features
- determining your own phone number

What Is a SIM Card?

Your SIM card (Subscriber Identity Module) contains your phone number, service details, and memory for storing Phone Book entries and messages. This means you can use your SIM card with any Iridium product for the Iridium satellite system, and all calls go on your account.

Note: Your phone has limited functionality without the SIM card.

SIM Card Protection

Keep your SIM card in your wallet or purse when you are not using it. This helps keep your personal information secure and gives you access to your service even if your phone is not available.

Note: The SIM card should have already been installed in your ComCenter by your service provider.

Caution: Avoid bending, scratching, or exposing your card to static electricity, water, or dirt.

Using additional SIM Card (Other than SIM card already in Iridium satellite phone)

Insert the SIM Card in the SIM card reader of the Car Kit. Make sure your phone is powered off before inserting or removing the SIM card. If you don't, you may damage the memory on your SIM card. Use of an additional SIM card would require the use of an optional SIM Card Reader/ Hang-up cup. For more information on the SIM Card Reader/ Hang-up Cup, please see section 'Use of an External SIM Card Reader/ Hang-up Cup' on page 18.

Insert the SIM Card (For use with SIM Card Reader/Hang-up cup)

1. Turn your unit off by pressing and holding the  key.
2. Make sure that the gold plate on the SIM card faces down and away from you, and then insert the SIM card into the slot in the hang-up cup as far as it will go.

Tip: Hold the SIM card so that the back (or blank) side of the card is facing you. The gold plate should be facing down. Insert the end with the gold plate first.



Remove the SIM Card (For use with SIM Card Reader/Hang-up cup)

1. Turn your unit off by pressing and holding the  key.
2. Pull the SIM card out of the slot in the hang-up cup.

Powering Up the ComCenter



Turn the Power On and Off

To turn your unit's power on:

1. Insert your SIM card. (See "Installing the SIM Card" on page 24.)
2. Press and hold  to turn the phone on and off.



Note: The SIM card should have already been installed in your ComCenter by your service provider.

When you turn your unit's power on, it performs a self-test to let you know it is operational. You may see a number of other power-on messages (see below).

When the  (no service) indicator disappears and the  (home system) indicator appears, you are ready to start calling.

Power-On Messages

Once your ComCenter is powered on, you may see on the Iridium handset:

| Message | Description |
|-------------------------|---|
| Searching... | The unit is attempting to establish communications with the satellite network. See “Accessing the Network” on page 90 for more information. |
| Registering... | Your unit is registering with the network. When the process is complete, you will see Registered. See “Accessing the Network” on page 90 for more information. |
| Enter Phone Unlock Code | Your unit was locked after the last use. Enter your four-digit unlock code and press  to proceed. See “Locking and Unlocking Your Phone” on page 82 for more information. |
| Enter PIN | Enter the four- to eight-digit SIM card PIN code provided by your service provider and press  to proceed. See “Protecting the SIM Card” on page 83 for more information. |
| Insert Card | Power off your unit; make sure your SIM card is inserted completely; and then power your unit on again. |
| Check Card | This message indicates that the SIM card is damaged or inserted the wrong way. |
| Blocked | If the SIM card PIN code is incorrectly entered three times in a row, your SIM Card becomes blocked. See “Unblock the PIN Code” on page 84 for instructions on how to unblock it. |

| | |
|---|--|
|  Blocked | <p>If the SIM card PIN2 code is incorrectly entered three times in a row, your SIM Card becomes blocked. See “Unblock the PIN2 Code” on page 86 for instructions on how to unblock it.</p> |
| <p>Bad Card See Supplier</p> | <p>Your SIM card has been damaged or incorrectly issued. Contact your service provider for information.</p> |



Placing a Call

To place a call, your ComCenter must be powered on, have a SIM card inserted, be unlocked, and be in contact with the satellite network. See “Accessing the Network” on page 90 for network information.

Dial a Number

1. Enter the number using the digit keys. As you begin entering digits, you will see Call? You must enter the phone number in international format: [international access code, 00, or +] [country code or Iridium country code] [phone number]

Note: If you are calling another Iridium satellite subscriber, use the Iridium code instead of the country code.

If you make a mistake, press  once to delete the last digit, or press and hold  to clear all digits.

2. Press . You will see Calling followed by the number you dialed.

With the ComCenter, the Smart Dial feature removes the need to enter in the '+' or '00' before the country code. For information on this, please see section on 'Smart Dial Feature' on page 20.

You will see either the flashing message Calling or the flashing messages Calling, Registering..., and the phone will play a series of setup tones.

If the call connects and is answered, Connected appears on the display for a few seconds, followed by End Call?. If the call does not connect, you may see one of the following messages:

| Message | Description |
|---|--|
| Call Failed System Busy Weak Signal | The phone is unable to access the network. Try again in a few minutes. |
| Restricted Area | You are in an area where you cannot make a call. |
| Redial? | See "Automatic Redial" on page 27. |

Automatic Redial



If the number or your network is busy, you will see Redial? for five seconds.

Press  to redial the number automatically.

Note: The maximum number of redial attempts is set by your service provider. If the call cannot be connected within this maximum, you will see the message *Redial Failed*.





Redial Last Number Called

Whenever your unit is on standby, you can redial the last number called:

1. Press  to display the last number dialed.
2. Press  again to place the call.

Dial Special Characters

You can insert special characters in your numbers:

| To enter... | Then... |
|---|--|
| 0 | Press  . |
| * | Press  . |
| + (for international calls) | Press and hold  . |
|  (for pause dialing) | Press and hold  . |

Dial a Number With Pauses

Refer to “Using Pauses in Numbers” on page 41 for information on dialing numbers with pauses.

Dial a Number from the Phone Book

Your phone contains a phone book that you can use to store names and telephone numbers. Once you have stored information in your phone book, you can save dialing steps by using:

- one-touch dialing
- an entry from a location
- an entry of a name
- one of the last ten numbers called

Refer to “Managing the Phone Book” on page 36.

Ending a Call

To end a call, perform one of the following tasks:





- Press  .



- Replace the handset in the hang-up cup if one is being used.

- Press .

What's My SIM Card Phone Number?

You can retrieve and display your phone number from your SIM card.

1. Press  until you see Phone Book, and then press  to select.
2. Press  until you see My Phone Number(s), and then press  to select. You will see your phone number.
3. Press and hold  to exit the menu.

Tip: Pressing   also brings up your phone number.

Note: If you do not see your number(s), they have not been programmed onto your SIM card. You just need to enter your phone number in for future reference. This can be done by following steps 1 and 2, and then pressing OK when the display shows “modify?”. Then enter in your phone number.

Receiving a Call

Receive a Phone Call





To receive a call, your ComCenter must be powered on, have a SIM card inserted, be unlocked, and be in contact with the satellite network. See “Accessing the Network” on page 90 for network information.

When you receive a call:

- Your unit rings.
- The handset displays Call, followed by Answer? on the next line.

To answer the call:

Remove the handset from the hang-up cup (if one is being used) by pressing in the release buttons.

Pick up the handset and Press  or any digit key
( -  wxyz,  or ). You will see

Connected.

If the call does not connect properly, you may see Call Failed. This indicates that the network signal is not strong enough.



Unanswered Calls

If you are away from your unit or choose not to answer a call, your handset displays the message Unanswered Call.

Personal Mailbox

Callers who are unable to reach you can leave numeric, text, and voice messages. The next time you register with the satellite network, you will receive these messages. Then you will have the option of returning the call or saving the message for later viewing.

For information on retrieving messages, see “Accessing Messages” on page 67.

Adjusting Earpiece Volume

To adjust earpiece volume:

- Increase the volume by pressing the upper volume key.
- Decrease the volume by pressing the lower volume key.

As you press the keys, the phone’s speaker demonstrates the new volume level. The bar graph in the display represents the volume level. The higher the graph, the louder the volume.



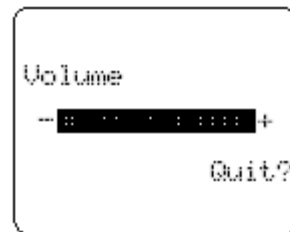

Tip: The volume keys are located on the side of the phone.



Adjusting Ringer Volume

Use this feature to adjust the volume of the ringer. The phone sounds the new volume level as you adjust it.

To adjust the ringer volume:

1. Press  until you see Phone Setup, and then press .
2. Press  until you see Adjust Ring Volume, and then press  to select.
3. Increase the volume by pressing the upper volume key.

Or

Decrease the volume by pressing the lower volume key.

4. Press and hold  to exit the menu.

Tip: You can also press  and then the up or down volume key to adjust ringer volume.

Using In-Call Features

Read this section to learn how to use In-Call menu features. The In-Call menu is displayed when you press



during a call. See “Using The In-Call Menu” on page 35 for more information.

What You Will Learn

- using call muting



Muting a Call

For privacy during a call, try muting the phone. You hear the party on the other end, but the other party does not hear you.

While in a call:

1. Press .

Or

2. Press  until you see Turn Mute on or off. Then press  to select-



or

3. Press the up arrow and then scroll until you get to option 4 – Mute Phone?

To unmute a call:

1. Press  again.

or

2. Press  until you see Turn Mute on or off. Then press  to select-

or

3. Press  and then scroll (using either  or  ) until you get to option 4 – *Mute Phone?*

Using the Menus

Many of your ComCenter's features are organized into lists of options called menus. There are three menus: the Options menu, the Quick Access menu, and the In-Call menu. Some of these options give you access to additional lists of options called submenus.

Learn how to navigate through your phone's three main menus. Once you become familiar with these menus and their features, go to "Customizing the Menu System" on page 97 for instructions on how you can personalize your menus.

What You Will Learn

- using the Options menu

- using the Quick Access menu

- using the In-Call menu







Using the Options Menus

The Options menu gives you access to the features and options included with your Iridium designed satellite unit.

Navigate the Options Menus

Learning how to use just a few keys enables you to move freely through the entire menu system.



| If you want to... | Then... |
|------------------------|--|
| enter the Options menu | <i>Press</i>  to access the Options menu. You will see the first available submenu. |







| | |
|---------------------------------|--|
| scroll through the Options menu | <ul style="list-style-type: none"> • Press  to scroll forward. • Press  or  to scroll backward or forward. |
| select options and submenus | Press  to select a menu option or submenu when that option or submenu name is displayed. |
| exit features and menus | <ul style="list-style-type: none"> • Press  to exit the feature or submenu. • Press and hold  to exit the Options menu. |

Note: If you press  during a call, you will see the In-Call menu that is described on page 35.

How the Handset Responds

As you scroll through the Options menu, you will see one of three questions on the bottom line of the display.



| If your phone asks... | Then... |
|-----------------------|--|
| View Options? | Press  to enter the submenu. |
| Select? | Press  to select the displayed feature. |
| Quit? | Press  to exit the feature. |

| | |
|--|---|
|  Completed | This indicates a feature has been activated. |
|  Failed | The display returns to the menu in a few seconds. |
| Enter PIN or Enter Name | Enter requested information. Then press  . |
|  Busy Try Later | You may have requested information while your phone was completing another task. |
|  | This indicates where you are in a menu. |
|  | Your unit may take a few seconds to request settings from the network. |

Customize the Options Menu

To personalize the Options menu—to hide and move features—see “Move Menu Features” on page 97.

Using the Quick Access Menu

The Quick Access menu is a way to keep your favorite menu options readily accessible. Each digit key,  1 to  , has a Quick Access feature assigned to it. See the chart on page 34 for the default setup.

If you know the number of the feature, activating that option takes only two button pushes! If you do not know the number or want to review your options, just scroll through the icon menu and read the tag attached to

each option.



Activate the Feature Directly

To access the feature directly:



Press , and then press the digit key of the feature.

Scroll to the Feature

To scroll to the feature:

1. Press .
2. Press  to scroll through the available features.









or

Press  or  to scroll backward and forward.

3. Press  to select a feature.

Default Quick Access Settings

The following features (and associated icons) are the default settings for the Quick Access menu.

| Key | Icon | Quick Access Feature |
|--------|---|---|
| 1 |  | <i>Find Name</i> searches your Unit. Book by the full name. |
| 2 abc |  | <i>Check Signal</i> checks the strength of the signal from the satellite network. |
| 3 def |  | <i>Call Voicemail</i> calls your Voicemail number to check your Voicemail. |
| 4 ghi |  | <i>Mute Phone</i> mutes the phone. |
| 5 jkl |  | <i>Lock Now</i> locks your phone immediately. |
| 6 mno |  | <i>Adjust Ring</i> displays and sets the incoming call ring tone volume. |
| 7 pqrs |  | <i>Read Messages</i> displays the newest message received |
| 8 tuvw |  | <i>Register Now</i> initiates a systematic manual search for a network on which to register. You must wait three minutes between registration attempts. |
| 9 wxyz |  | <i>Forward On/Off</i> activates or deactivates unconditional call forwarding depending on the current setting. |

Customize the Quick Access Menu

See “Personalizing the Quick Access Menu” on page 92 for instructions on how to customize the menu.

Using The In-Call Menu

This menu lets you access specific features while you are in a call. Because this menu is not available until you are actually in a call, you cannot review it off-line.

Entering the In-Call Menu

While you are in a call:

Press  to view the In-Call menu features.

In-Call Menu Features

The In-Call menu provides access to placing a call on Mute.

| | |
|--------------------|---------------------|
| single active call | Turn Mute on or off |
|--------------------|---------------------|

Managing the Phone Book

Your satellite phone can store up to 100 names and numbers, and your SIM card expands memory capacity even more.

Use the dedicated keys or the Options menu to access the same functions. With the Options menu you can also access Phone Book maintenance and security features.

What You Will Learn

- recalling and storing phone numbers
- organizing the Phone Book
- accessing automated calling systems
- storing phone number prefixes
- restricting calls with fixed dialing
- editing the memory information
- viewing your own phone number



Entering the Phone Book Menu

To enter the Phone Book menu:

1. Press  to open the Options menu.

2. Press  to scroll forward.

or

Press  or  to scroll backward or forward.

3. Press  when you see:

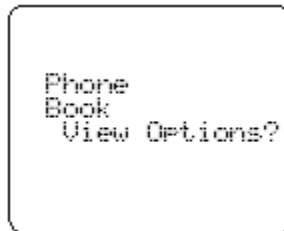

4. Press  to scroll through the submenu.

or

Press  or  to scroll backward or forward through the submenu.

What's on the Phone Book Menu?

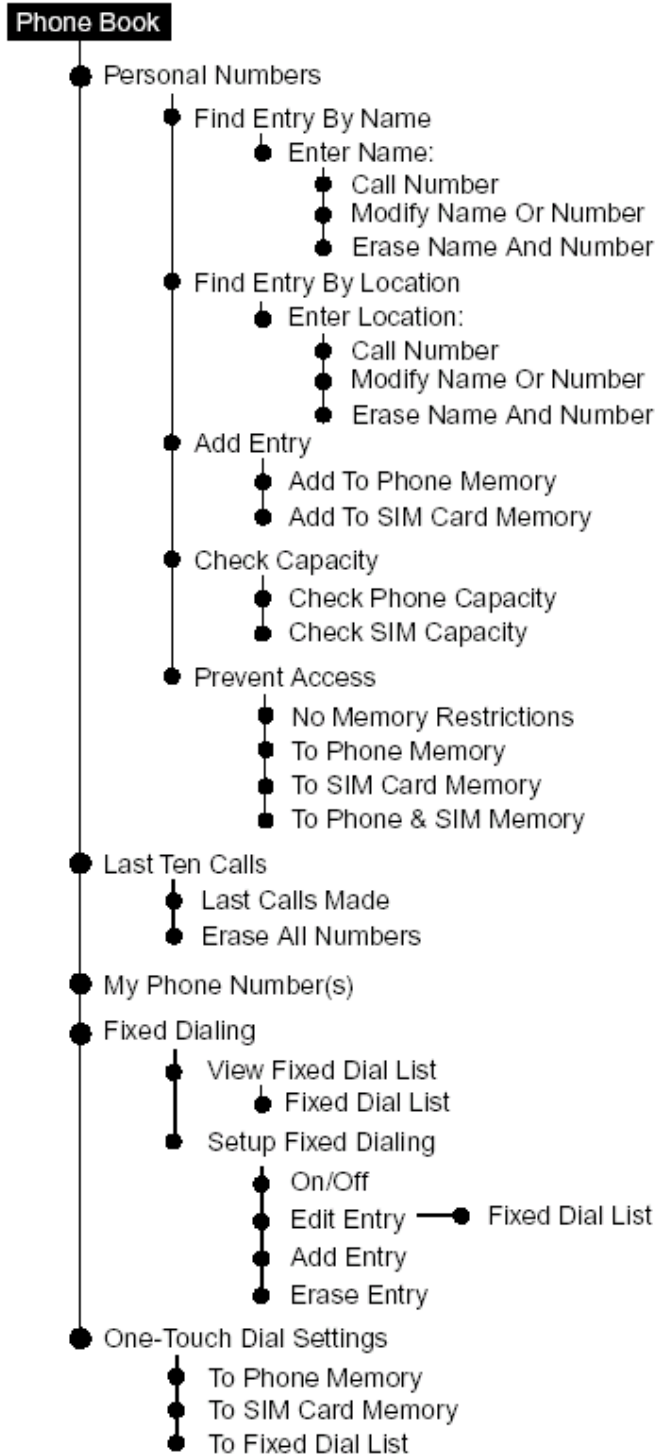

Organizing Your Phone Book

Each name and phone number in your Phone Book is stored in a numbered memory location. The satellite phone has two types of memory—phone memory and SIM card memory.

| | <i>Phone Memory</i> | <i>SIM Card Memory¹</i> |
|--|---------------------|------------------------------------|
| Personal Numbers | 100 entries | 155 entries |
| Fixed Dial Numbers | No entries | 40 entries |
| Phone Number Digits | 32 | 20 |
| Name Characters | 16 | 16 |
| Location Numbers | 1-100 | 101-255 |
| ¹ SIM card capacity varies depending upon the card issued by your service provider. | | |

Your phone's memory can seem overwhelming if you do not have a strategy for organizing your Phone Book. Begin setting up your Phone Book by asking yourself three questions:

Which numbers do I call most?

Make a list of the numbers you call most frequently. You will probably want to store these numbers in the first nine memory locations of your Phone Book. You can then dial them with a single keystroke by using One-Touch dialing.

When do I use these numbers?





Group the numbers on the list according to when you use them. Most people call a different set of numbers during the day than they do in the evening and on weekends. You can switch one-touch dialing to your phone's memory (locations 1–9), your SIM card's memory (locations 101–109), or to your fixed dial list (locations 1–9). Store your evening and weekend numbers on one type of memory and your daytime numbers on another.

Which numbers do I need to keep secure?

Use your SIM card to store the numbers you need to keep secure, like the numbers of friends and family members. Because your SIM card is the size of a credit card, you can easily keep it securely in your wallet when you are not using it. If you wish, you can even require a PIN code every time your SIM card is inserted into any phone. (To deactivate your PIN code, see “Activate and Deactivate the SIM Card PIN Code” on page 83.) Store more public numbers, like business associates and travel agents in your phone's memory.

Tip: If you have many entries, group them in blocks of ten to make them easier to find.





Getting to Personal Numbers...

1. Press  until you see Phone Book, and then press .
2. Press  until you see Personal Numbers, and then press .
3. Press  to scroll to one of the features described below.

Storing Names and Numbers

Add an Entry

Use the Options Menu

1. Follow the steps in “Getting to Personal Numbers...” to get to Add Entry, and then press .
2. Press  to scroll to Add to Phone Memory or Add to SIM Memory.
3. Press  to select. You will see Enter Number.
4. Enter a number, and then press . You will see Enter Name.
5. Enter a name (see “Entering Names” on page 40), and then press . You will see Enter Location.

6. Enter a location number, 1-100 for phone memory or 101-255 for SIM memory*, and then press .

You will see Stored XXX.

or

Press  to select the next available location. You will see Stored XXX.

7. Press and hold  to exit the menu.



Tip: Numbers must be entered in international format.

* SIM memory is dependent on your SIM card.

Use the Dedicated Keys

1. Enter the phone number you want to store.

2. Press  to begin storing.

3. Press  to scroll to the desired memory type Add to SIM Card Memory or Add to Phone Memory, and then press . You will see Enter Number, followed by the number you entered.

4. Press  to accept the number. You will see Enter Name.

5. Enter a name (see “Entering Names” on page 40), and then press . You will see Enter Location.

6. Enter a three-digit location number, and then press . You will see Stored XXX.

or

Press  to store the entry in the next empty memory location. You will see Stored XXX.

Tip: If you have more than one number for the same person, try attaching a descriptive tag to the name, like Home, Office, or Mobile.

Adding Entry Messages

When you enter the location number for your entry, you may see one of these messages:



| Message | Description |
|--------------|---|
| Stored XXX | You have stored the entry. |
| Range XXX-XX | You have chosen a memory location outside the appropriate range. Enter a new number within the range listed on the display. |
| Overwrite? | You have chosen an occupied location. Press  to overwrite the location or press any other key to try another location. |

Entering Names

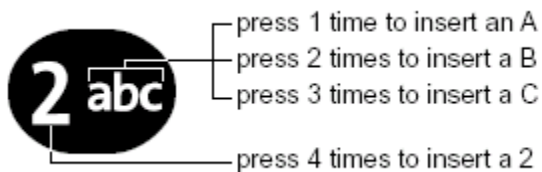
You can use the keypad to produce any letter in the alphabet. For example, press  to enter the letters A, B, or C, as shown:





Enter Characters

1. Enter a letter by pressing a key as many times as necessary.
2. Press  or  to advance the cursor.
3. Repeat steps 1 and 2 as many times as necessary, and then press .

Tip: Press and hold any numeric key to toggle between uppercase and lowercase characters.

Correct an Entry

To make a change:

1. Press  or  to scroll to the character you want to delete.
2. Press  to delete one character at a time.

or

Press and hold  to clear the display.

Available Characters

Use this chart as a guide for producing characters:

1 Space . 1 ? ! , @ _ & : " () ' ˆ ı % £ \$
Space . 1 ? ! , @ _ & : " () ' ˆ ı % £ \$

2 abc A B C 2 Ä Å à æ ß ç
a b c 2 ä å à æ ß ç

3 def D E F 3 Δ é è Φ
d e f 3 Δ é è Φ

4 ghi G H I 4 Γ ì
g h i 4 Γ ì

5 jkl J K L 5 Λ
j k l 5 Λ

6 mno M N O 6 Ñ Ò ø ò Ω
m n o 6 ñ ò ø ò Ω

7 pqrs P Q R S 7 Π ß Σ
p q r s 7 π ß Σ

8 tuv T U V 8 Θ Ů ù
t u v 8 θ ů ù

9 wxyz W X Y Z 9 Ξ Ψ
w x y z 9 ξ ψ

0+ + - 0 x * / = > < #
+ - 0 x * / = > < #

The upper line for each key shows the uppercase characters. The lower line for each key shows the lowercase characters.

Using Pauses in Numbers

When you call automated systems, a recorded message prompts you for numbers such as PIN numbers and account numbers. You can store these numbers in the same memory location as the automated system's access number. Separate the numbers with "pauses"—special characters that tell your phone to wait a few seconds before sending additional numbers—and store the string in the same way you would other numbers.

Enter Pauses in Numbers

1. Enter the phone number you use to access the automated system.
2. Press and hold . You will see a pause character (Ü) inserted into the number entry.
3. Enter the next group of numbers. For example, enter your PIN number. If the automated system requires a * or #, enter those symbols, too.
4. Repeat steps 2 to 3 as many times as necessary.
5. To store the entry follow the procedures in "Add an Entry" on page 48.

Tip: You can store 33 characters in a phone memory location, or 20 characters in a SIM card memory location. A pause is equal to one character.

Dial Numbers With Pauses

To dial a number with pauses:

1. Recall the entry. (See “Locating Entries” on page 43.)
2. Press  to place the call. The first pause in the number waits until the call is answered. When the automated system answers, your phone waits a few seconds and then automatically sends the next set of numbers, then the next, until all numbers are sent.

Using Phone Number Prefixes

You can save time when you dial by storing the prefixes that you often use. This is sometimes called “post scripting.” Your satellite phone allows you to change or add to Phone Book entries without overwriting them.

Store a prefix in your Phone Book just as you would any other number. See “Storing Names and Numbers” on page 39.

Use a Stored Prefix

To use a stored prefix:

1. Recall the prefix from your Phone Book. (See “Locating Entries” on page 43.)

2. Add the remaining numbers.

3. Press  to place the call.

Tip: Try naming the prefix by area, like Downtown, Suburbs, or Germany.

Change Entry to a Similar Number

To change an entry to a similar number:

1. Recall the number from your Phone Book. (See “Locating Entries” on page 43.)

2. Press  to delete the unwanted digits.

3. Enter the replacement digits.

4. Press  to place the call.

Locating Entries

Find an Entry by Name

Search your Phone Book by the first few letters of the entry.

Note: If you have restricted access to either SIM card or phone memory, those entries will not be available. For more information, see “Preventing Access to the Phone Book” on page 46.

1. Follow the steps in “Getting to Personal Numbers...” to get to Find Entry By Name, and then press  to select. You will see Enter Name.

2. Enter one to three characters of the entry, and then press . If necessary, scroll to the entry you are looking for.

3. Press  to access options for that entry, and then proceed to “Calling, Modifying, or Erasing an Entry” on page 44.

Tip: Your phone sorts SIM card memory and phone memory together alphabetically.

Find an Entry by Location

If you know the location number of the entry, here is an easy way to recall it.



Use the Options Menu

1. Follow the steps in “Getting to Personal Numbers...” to get to Find Entry By Location, and then press  to select. You will see Enter Location.

2. Enter the location number, and then press . You will see the entry displayed. If you enter an empty location number, you will see Location XXX is Empty. Your phone then selects the next largest available location. If there are no numbers stored, you will see No Numbers Stored.

3. Press  to access options for that entry, and then proceed to “Calling, Modifying, or Erasing an Entry” on page 44.



Use the Dedicated Keys

1. Press .
2. Enter the three-digit location number of the entry, and then press . If you enter an empty location number, you will see Location XXX is Empty. Your phone then selects the next largest available location. If there are no numbers stored, you will see No Numbers Stored.
3. Press  to call the displayed entry. You will see the number followed by Calling.



Calling, Modifying, or Erasing an Entry

Once you have selected a Phone Book entry, you can call, change, or erase that entry.

Call a Selected Entry

1. Find an entry, and then press . See “Locating Entries” on page 43.
2. Press  until you see Call Number, and then press . You will see Calling followed by the number you dialed.

Modify a Name or Number

1. Find an entry, and then press . See “Locating Entries” on page 43.
2. Press M until you see Modify Name or Number, and then press . You will see Edit Number, followed by the phone number stored in that entry.



3. Enter changes to the number, and then press  . You will see the name stored in that entry.

4. Enter changes to the name, and then press  . You will see Modified XXX.





Tip: For help entering letters or changing entries, see “Entering Names” on page 43.

Erase a Name and Number

1. Find an entry, and then press  . See “Locating Entries” on page 43.





2. Press  until you see Erase Name and Number, and then press  . You will see Erased xxx.

Getting to Personal Numbers...





1. Press  until you see Phone Book, and then press .
2. Press  until you see Personal Numbers, and then press .
3. Press  to scroll to one of the features described below.

Checking Phone Book Capacity

Use this feature to see how many available memory locations you have in either SIM card memory or phone memory.





1. Follow the steps in “Getting to Personal Numbers...” to get to Check Capacity, and then press  to select.
2. Press  until you see Check Phone Capacity or Check SIM Capacity, and then press . You will see XXX Unused Locations.
3. Press and hold  to exit the menu.

Getting to Personal Numbers...

1. Press  until you see Phone Book, and then press .
2. Press  until you see Personal Numbers, and then press .
3. Press  to scroll to one of the features described below.

Preventing Access to the Phone Book

You may want to restrict memory access when loaning your phone to others. You can choose to prevent access to the phone memory, SIM memory, or both.





1. Follow the steps in “Getting to Personal Numbers...” to get to Prevent Access, and then press  to select.
2. Press  until you see the restriction type you desire: No Memory Restrictions, To SIM Card Memory, To Phone Memory, or To Phone & SIM Memory.
3. Press  to select the displayed option. You will see Enter Security Code.
4. Enter security code. Enter your six-digit security code. You will see Completed.
5. Press and hold  to exit the menu.

Tip: The factory default security code is: 000000.

Notes:

- If you prevent access to both your phone memory and SIM memory and then try to access an entry, you will see Restricted.
- If you restrict access to either your phone memory or SIM memory and try to access an entry stored in that type of memory, you will see a list of the entries that are not restricted.

Getting to Fixed Dialing...

1. Press  until you see Phone Book, and then press .
2. Press  until you see Fixed Dialing, and then press .
3. Press  to scroll to one of the features described below.

Restricting Phone Use





With the fixed dialing feature, you can restrict calling on your phone to a list of numbers that you create. When this feature is active, you can only call numbers or use prefixes (for example, country codes or area codes) that exactly match those that are stored in your list. You can store up to 40 entries on your fixed dial list. These entries are stored on your SIM card.

Activate Fixed Dialing

Use this option to activate fixed dialing.

Note: The fixed dialing feature restricts access to your SIM memory.

1. Follow the steps in “Getting to Fixed Dialing...” to get to Setup Fixed Dialing, and then press  to select. You will see Enter PIN2.

2. Enter code. Enter your SIM card PIN2 code, and then press .
3. Press  until you see On or Off, and then press . You will see Completed.
4. Press and hold  to exit the menu.

Tip: You should have received your SIM card PIN2 code from your service provider.

Getting to Fixed Dialing...

1. Press **MENU** until you see Phone Book, and then press **OK**.
2. Press **MENU** until you see Fixed Dialing, and then press **OK**.
3. Press **MENU** to scroll to one of the features described below.

Add an Entry

To add an entry:







1. Follow the steps in “Getting to Fixed Dialing...” to get to Setup Fixed Dialing, and then press **OK** to select. You will see Enter PIN2.
2. Enter code. Enter your SIM card PIN2 code, and then press **OK**.
3. Press **MENU** until you see Add Entry, and then press **OK**. You will see Enter Number.
4. Enter the number, and then press **OK**. You will see Enter Name.
5. Enter the name, and then press **OK**. You will see Enter Location.
6. Enter a location number, and then press **OK**. You will see Completed.
7. Press and hold **C** to exit the menu.

Tip: Phone numbers must be in international format.





Tip: See “Entering Names” on page 40 for help entering letters.

Erase an Entry

To erase an entry:









1. Follow the steps in “Getting to Fixed Dialing...” to get to Setup Fixed Dialing, and then press  to select. You will see Enter PIN2.
2. Enter code. Enter your SIM card PIN2 code, and then press .
3. Press  until you see Erase Entry, and then press  to select. You will see the first entry in your fixed dial list.
4. Press  to scroll to the number you wish to erase. You will see Erase?.
5. Press  to confirm. You will see Completed.
6. Press and hold  to exit the menu.

Getting to Fixed Dialing...

1. Press  until you see Phone Book, and then press .
2. Press  until you see Fixed Dialing, and then press .
3. Press  to scroll to one of the features described below.

Edit an Entry

To edit an entry:

1. Follow the steps in “Getting to Fixed Dialing...” to get to Setup Fixed Dialing, and then press  to select. You will see Enter PIN2.
2. Enter code. Enter your SIM card PIN2 code, and then press .
3. Press  until you see Edit Entry, and then press  to select. You will see the first entry in your fixed dial list.
4. Press  to scroll to the entry you want to change, and then press . You will see the current number for that location.
5. Enter changes to the number, and then press . You will see the current name for that location.
6. Enter changes to the name, and then press . You will see the current location.

7. Enter a new location, and then press  . You will see Completed.

8. Press and hold  to exit the menu.

View Your Fixed Dialing List



This feature enables you to review, but not change, your fixed dial list.

1. Follow the steps in “Getting to Fixed Dialing...” to get to View Fixed Dial List, and then press  to select. You will see the first number on your fixed dial list.

2. Press  to scroll through the numbers on your fixed dial list.





3. Press and hold  to exit the menu.

Getting to Phone Book Features...

1. Press  until you see Phone Book, and then press .
2. Press  to scroll to one of the features described below. You will see the feature name, followed by Select?.

Viewing the Last Ten Numbers Dialed

Don't worry about forgetting the number you dialed earlier. The last ten numbers you dialed are saved.

1. Follow the steps in "Getting to Phone Book Features..." to get to Last Ten Calls, and then press  to select.
2. Press  to scroll to Last Calls Made or Erase All Numbers, and then press  to select.
3. If you select Last Calls Made, press  to scroll to the number you are looking for, and then press  to place a call to that number.

or

If you select Erase All Numbers, you will see Completed.



4. Press and hold  to exit the menu.



Tip: If you want to add a number from Last Ten Calls to your Phone Book, press  when the number is **displayed**, then follow the steps in “Storing Names and Numbers” on page 39.

Viewing and Modifying Your Phone Numbers

View Your SIM Phone Number(s)

You can program fax, data, and other types of phone numbers into your SIM card in addition to your voice phone number. Use this feature to view your phone number(s). You can have up to five phone numbers.





1. **Follow the steps in** “Getting to Phone Book Features...” to get to My Phone Number(s).
2. **Press**  to select. You will see your phone’s voice number followed by Modify?.
3. **Press**  to scroll through your numbers.
4. **Press and hold**  to exit the menu.

Tip: Pressing   also brings up your phone number.

Note: If you do not see your number(s), they have not been programmed onto your SIM card. Contact your service provider for more information.

Modify Your Phone Numbers

If you have recently switched your phone number, use this feature to quickly store recent information.

- 1. Complete the steps in “View Your SIM Phone Number(s)” on page 50 to get to the number you want to modify.**
- 2. Press ** to modify the number. You will see Edit Number followed by the number for the selected entry.
- 3. Enter changes to the number, and then press .** You will see Edit Name followed by the name for the entry selected.
- 4. Enter changes to the name (see “Entering Names” on page 40) and then press .** You will see Stored.
- 5. Press and hold ** to exit the menu.

Getting to Phone Book Features...

1. Press **MENU** until you see Phone Book, and then press **OK**.
2. Press **MENU** to scroll to one of the features described below. You will see the feature name, followed by Select?.

One-Touch Dialing

One-touch dialing enables you to place calls instantly. You can choose to dial the phone numbers in the first nine memory locations in either your SIM memory, phone memory, or your fixed dial list. You choose which type of memory you want to be active with this feature.

Set Up One-Touch Dialing

1. Follow the steps in “Getting to Phone Book Features...” to get to One-Touch Dial Setting, and then press **OK** to select.
2. Press **MENU** to scroll through To Phone Memory, To SIM Card Memory, or To Fixed Dial List, and then press **OK** to select the displayed option. You will see Completed.
3. Press and hold **C** to exit the menu.

Use One-Touch Dialing

Using one-touch dial is easy—just press and hold a keypad digit! To use one-touch dialing:

Press and hold the appropriate digit key.

For example, press and hold  to dial the number stored in location 2 of your phone memory, location 2 of your fixed dial list, or 102 of your SIM memory, depending on your setting.

Tip: You do not need to press  to call the number when you are using one-touch dialing.

Using Calling Features

This chapter describes call-related features. Many of these features are network features that you must subscribe to in order to access.

What You Will Learn



- showing the strength of the signal your phone is receiving
- activating/deactivating the Pending Call Drop signal
- forwarding calls when you are not available
- restricting use of your phone

Entering the Call Related Features Menu

To enter the Call Related Features menu:

1. Press  to open the Options menu.
2. Press  to scroll forward.

or

Press  or  to scroll backward or forward.

3. Press  when you see:

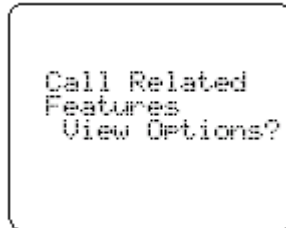

4. Press  to scroll through the submenu.

or

Press  or  to scroll backward or forward through the submenu.



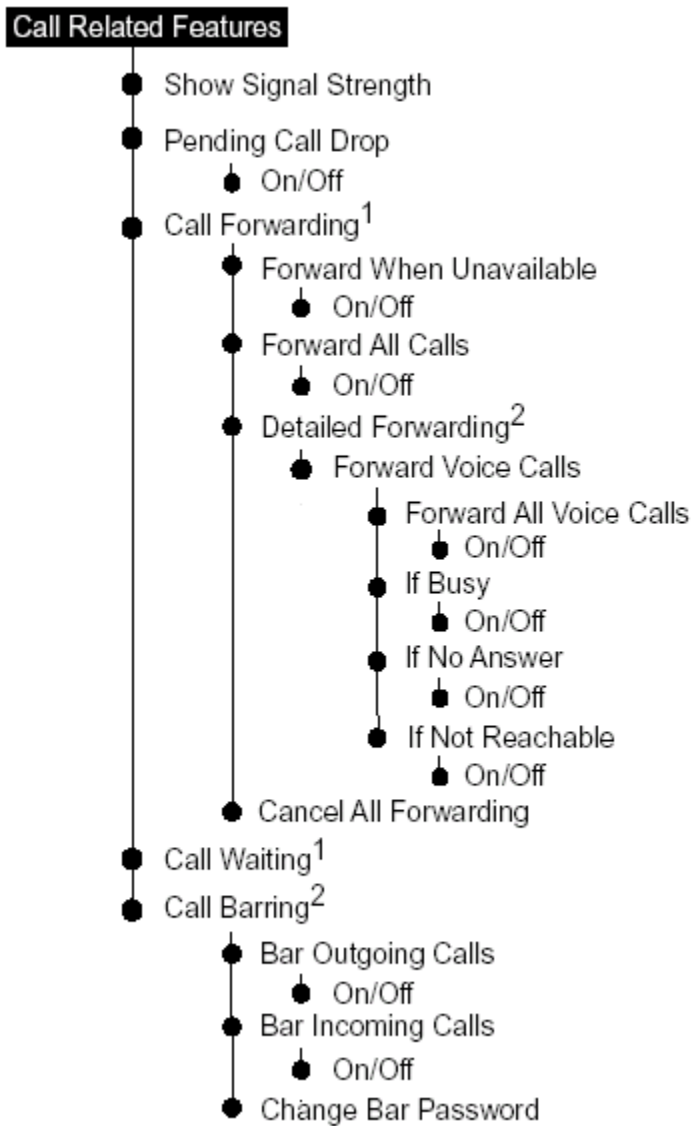

What's on the Call Related Features Menu?



1 This feature is network and subscription dependent.

2 This feature is network and subscription dependent. It is available only when the extended menu is activated.

Getting to Call Forwarding...

1. Press  until you see Call Related Features, and then press .
2. Press  until you see Call Forwarding, and then press .
3. Press  to scroll to one of the features described below.



Forward Calls When Unavailable

Use this feature when you can't answer a call. You must subscribe to this network feature through your service provider(s).

To activate this feature:



1. Follow the steps in "Getting to Call Forwarding..." to get to Forward When Unavailable, and then

press  to select.

2. Press  to scroll to On or Off, and then press  to select.

- If you select On, continue with **step 3**.

- If you select Off, continue with **step 5**.

3. Press  to scroll to Voicemail or Other Number, and then **press**  to select.

- If you select Voicemail, continue with **step 5**.

- If you select Other Number, then you will see Enter Number. Continue with **step 4**.

4. Enter the number you want calls forwarded to, and then **press** . Your phone takes a moment to request the setting from the network, and then you will see Call Forward On.

5. Press and hold  to exit the menu.



Tip: If you have not yet stored a voicemail number, go to page 65 to learn how.

Forward All Your Calls

When you select this option, all your calls are forwarded to the number you choose. Your phone does not ring. You must subscribe to this network feature through your service provider(s).

To activate this feature:

1. Follow the steps in “Getting to Call Forwarding...” to get to Forward All Calls, and then **press**  to select.

2. Press  to scroll to either On or Off, and then **press**  to select.

- If you select On, continue with **step 3**.

- If you select Off, continue with **step 5**.

3. Press  to scroll to Voicemail or Other Number, and then **press**  to select.

- If you select Voicemail, continue with **step 5**.





- If you select Other Number, then you will see Enter Number. Continue with **step 4**.

4. Enter the number you want all your calls forwarded to, and then **press** . Your phone takes a moment to request the setting from the network, and then you will see Call Forward On.

5. Press and hold  to exit the menu.

Tip: If you have not yet stored a voicemail number, go to page 65 to learn how. **step 5**.

Getting to Call Forwarding...



1. Press  until you see Call Related Features, and then press .
2. Press  until you see Call Forwarding, and then press .
3. Press  to scroll to one of the features described below..

Detailed Call Forwarding

Detailed Call Forwarding lets you select the specific situations when you want your calls forwarded. The settings you select in Forward When Unavailable and Forward All Calls override the settings you select here.



You must subscribe to this network feature through your service provider(s).

Note: This feature is available only when the extended menus are activated. See “Activating Extended Menus” on page 87 for more information.

1. Follow the steps in “Getting to Call Forwarding...” to get to Detailed Forwarding, and then press  to select.
2. Press  to scroll to Forward Voice Calls, then press  to select.

3. Press  to scroll to the option you desire Forward All Voice Calls, If Busy, If No Answer, or If Not Reachable.

4. Press  to select the displayed option.

5. Press  to scroll to either Voicemail or Other Number, and then press .

- If you select Voicemail, continue with **step 7**.

- If you select Other Number, then you will see Enter Number. Continue with **step 6**.





6. Enter the number you want calls forwarded to, then press . Your phone takes a moment to request the setting from the network, then displays Call Forward On.

7. Press and hold  to exit the menu.

Tip: For information on retrieving messages, see “Accessing Messages” on page 67.

Tip: If you have not yet stored a voicemail number, go to page 65 to learn how.

Getting to Call Forwarding...

1. Press  until you see Call Related Features, and then press .
2. Press  until you see Call Forwarding, and then press .
3. Press  to scroll to one of the features described below.

Cancel All Forwarding

Use this option to clear all Call Forwarding settings.

To cancel Call Forwarding settings:



1. Follow the steps in “Getting to Call Forwarding...” to get to Cancel All Forwarding, and then press

 to select.

You will see Call Forward Off. All Call Forwarding settings are now set to Off.

2. Press and hold  to exit the menu.

Getting to Call Related Features...

1. Press  until you see Call Related Features, and then press .
2. Press  to scroll to one of the features described below. You will see the feature name, followed by Select?.

Showing Signal Strength

Use this feature to check the strength of the signal that your phone is receiving from the Iridium satellite network.

1. Follow the steps in “Getting to Call Related Features...” to get to Show Signal Strength.

2. Press  to select. You will see:

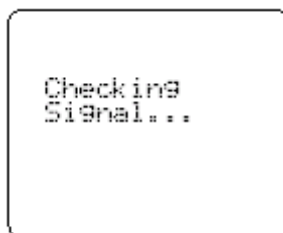



After a few seconds, if the phone is able to locate a signal, the signal strength indicator appears in the upper left corner of the display.



The signal strength meter remains on the display for several seconds. If the phone cannot locate a signal, you will see Weak Signal.

3. Press and hold  to exit the menu.





Getting to Call Related Features...

1. Press  until you see Call Related Features, and then press .
2. Press  to scroll to one of the features described below. You will see the feature name, followed by Select?.





Deactivating Pending Call Drop Signal

Under rare circumstances, due to system overcapacity or a satellite outage, a satellite may not be available to take your call. When this happens, your phone notifies you with a series of three consecutive tones and displays Pending Call Drop. The tones continue periodically until a new satellite moves into range or the call is dropped.

To deactivate the alert tones:

1. Follow the steps in the “Getting to Call Related Features...” to get to Pending Call Drop, and then press  to select.
2. Press  to scroll to either On or Off, and then press  to select.
3. Press and hold  to exit the menu.

Getting to Call Barring...

1. Press  until you see Call Related Features, and then press .
2. Press  until you see Call Barring, and then press .
3. Press  to scroll to one of the features described below. You will see the feature name, followed by Select?.

Restricting Calls with Call Barring





You can use call barring to restrict both incoming and outgoing calls. Call barring is useful if you are loaning your phone to others or when you wish to control incoming calls. When you change one of your call barring settings, your phone takes a few seconds to request the setting from the network.

Note: This feature is available only when the extended menus are activated. See “Activating Extended Menus” on page 87 for more information.

Bar Outgoing Calls

This setting enables you to receive incoming calls but prevents outgoing calls.

To activate this feature:





1. **Follow the steps** in “Getting to Call Barring...” to get to Bar Outgoing Calls, and then **press**  to select.
2. **Press**  to scroll to On or Off, and then **press**  to select. You will see Enter Password.
3. **Enter your bar password**, and then **press** . You will see Completed.
4. **Press and hold**  to exit the menu.

Tip: Your service provider gives you a bar password.

Bar Incoming Calls





This setting allows you to place calls, but refuses incoming calls. Callers hear a recording telling them you are unavailable. To be sure not to miss a call see “Detailed Call Forwarding” on page 57.

To activate this feature:

1. **Follow the steps** “Getting to Call Barring..” to get to Bar Incoming Calls, and then **press**  to select.
2. **Press**  to scroll to On or Off, and then **press**  to select.
3. **Enter your bar password**, and then **press** . You will see Completed.
4. **Press and hold**  to exit the menu.





Tip: Your service provider gives you a bar password. You will see Enter Password.

Getting to Call Barring...

1. Press  until you see Call Related Features, and then press .
2. Press  until you see Call Barring, and then press .
3. Press  to scroll to one of the features described below. You will see the feature name, followed by Select?.

Change Bar Password

When you subscribe to call barring, your service provider gives you a four-digit bar password. Use this feature to change it to something easy to remember.

1. Follow the steps in “Getting to Call Barring...” to get to Change Bar Password, and then press  to select. You will see Enter Password.
2. Enter bar password, and then press . You will see Enter New Password.
3. Enter the new bar password, and then press .
4. Enter the new bar password again to confirm, and then press .
5. Press and hold  to exit the menu.

Tip: If you are changing the password for the first time, use the password supplied by your service provider.

Using Message Services

Did you know that you can receive voicemail and fax notification messages and numeric and text messages through your Personal Mailbox service—wherever in the world you may be? You can also send text messages to other phones as well as e-mail addresses. Wherever you are, you will have instant reference to all your communication.

What You Will Learn

- checking your voicemail messages
- reading, saving and deleting messages
- how to use Short Message Service – Mobile Originated (SMS-MO)

Entering the Messages Menu

To enter the Messages menu:



1. Press  to access the Messages submenu directly, and then go on to **step 4**.

or

Press  to open the Options menu and then go on to **step 2**.

2. Press  to scroll forward.

or

Press  or  to scroll backward or forward.

3. Press  when you see:

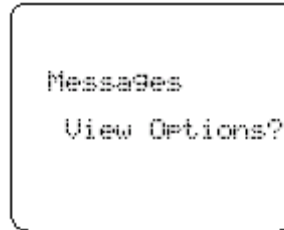

4. Press  to scroll through the submenu.



or

Press  or  to scroll backward or forward through the submenu.

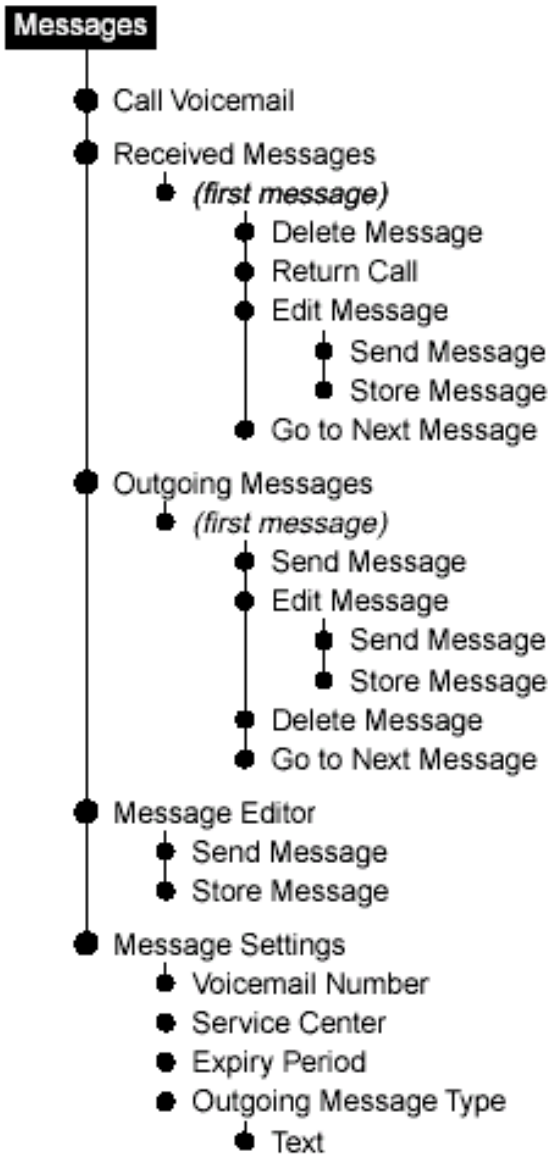
What's on the Messages menu?



Getting to Message Features...

1. Press  until you see Messages, and then press .
2. Press  to scroll to one of the features described below. You will see the feature name, followed by Select?.



Checking Your Voicemail

Important: This feature makes checking your voicemail simple.

1. Follow the steps in “Getting to Message Features...” to get to Call Voicemail.
2. Press  to select. You will see your voicemail number followed by Calling. If you have not previously stored a voicemail number, then you will see No Number Available. See “Storing Your Voicemail Number” on page 65 for instructions on how to enter a number.

Storing Your Voicemail Number

To store a voicemail number:

1. Follow the steps “Getting to Message Features.” to get to Message Settings, then press  to select.
2. Press  to select Voicemail Number. You will see Enter Voicemail Number followed by your current voicemail number. If this is the first time you have stored a number, continue with to **step 4**.

3. Press **C** to clear one digit at a time, or press and hold **C** to erase the entire number.

4. Enter the new number, and then press **OK**. You will see Completed.

5. Press and hold **C** to exit the menu.

Tip: Use pause dialing to store your voicemail access and PIN numbers together. See “Using Pauses in Numbers” on page 41.

Managing Your Messages (This is only accessible when using the Iridium handset)

How Your Phone Notifies You of Messages

If your phone is powered on, it notifies you of received messages in the following ways:

- **An alert sounds.**

- Your phone beeps three times to inform you of an incoming message.

- The  (message) indicator is displayed.

- **The message is displayed immediately** if the message is a fax or voicemail notification message. The message remains on the display for several seconds.

or

Message Read Now? **is displayed** if the message is an alphanumeric, text message of up to 160 characters. For more information see “Read a New Message” on page 67.

How Messages Are Stored

Your phone stores all messages on your SIM card. The total number of messages that you can store depends on your service provider.

If the message indicator is flashing, your SIM card is full. See “Delete Messages” on page 68 to make room for the new message.





What Messages Contain

You can receive short text or numeric messages in your Personal Mailbox. Text messages may contain up to 160 characters. Numeric messages— typically phone numbers—may contain up to 20 digits.

Your personal mailbox works along with Call Forwarding. For more information see “Personal Mailbox” on page 30, and the Call Forwarding feature descriptions on pages 53-58. Messages contain multiple screens with the following information:

- the message
- the date and time the message was sent
- the phone number (if available) from which the message was sent

Accessing Your Messages...



1. Press  until you see Messages, and then press .
2. Press  until you see Received Messages, and then press .
3. Press  to scroll to one of the features described below.

Accessing Messages

Read a New Message

Notification Messages

When you receive an incoming fax or voicemail notification message, it automatically scrolls across your screen. You can:

- Press  to store it on your SIM card.
- Press  to delete it.

Text Messages

When you receive a new alphanumeric message, you will see Message Read Now? To read it:

1. Press  and continue with **step 2**.

or

Press  to read the message later. See “Read a Stored Message” on page 68.

2. Press  to move forward through a message one screen at a time.

3. Press  to access options for that entry, then proceed to page 69.

Notes:

- If the message storage space on your SIM card is full, you will not be able to store a message for later retrieval. Use the delete message feature to make room for new messages on your SIM card.

Read a Stored Message

To read a stored message:

1. Follow the steps in “Accessing Your Messages...” to enter the message center. If you have messages you will see the number of messages stored. If you do not have any messages, you will see No Messages.

2. Press  to move forward through a message one screen at a time.

3. Press  to access options for that entry, and then proceed to page 69.



or

Press and hold  to exit the menu.

Delete Messages





Use this option to make room for new messages:

1. **Follow the steps** in “Go to the Next Message” on page 69 until you see the message you want to delete, and then press .

2. Press  until you see Delete Message, and then press . You will see Message Deleted.

3. Press and hold  to exit the menu.



Accessing Your Messages...

1. Press  until you see Messages, and then press .
2. Press  until you see Received Messages, and then press .
3. Press  to scroll to one of the features described below.

Go to the Next Message

To go to the next message:

1. Follow the steps in “Read a Stored Message” on page 68.

2. Press  until you see Go To Next Message and then press .

You will see the next message. If you are at the end of your message list you will see the first message again.





3. Press  to move forward through a message one screen at a time.

4. Repeat steps 2 to 3 until you have read all your messages.

5. Press and hold  to exit the menu.

Managing Outgoing Messages (SMS-MO)(only accessible with Iridium handset)

Getting to Message Features...

1. Press  to go directly to the Messages menu.
or
Press  until you see Messages, and then press .
2. Press  to scroll to one of the features described below.

You can create a new message and send it immediately, or store it in an outgoing messages list for later use. You can also edit a message that you have received, then send and/or save the modified message. Messages are created and edited in the message editor.

Message Editor

The message editor lets you create a new message or modify a stored message (received or outgoing). You use the keypad to create or edit a message. You can produce any letter in the alphabet by pressing the

appropriate key. For example, press  to enter the letters A, B, or C, as shown:

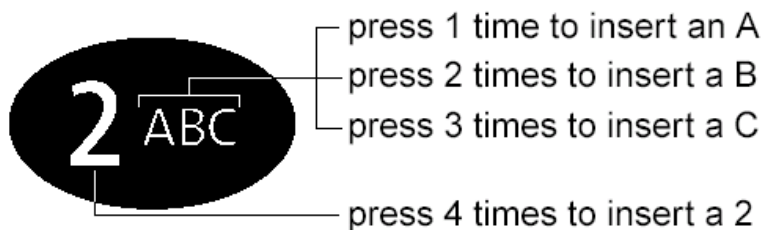

For a complete list of the characters you can enter from the keypad, see page 41.

Create a New Message (SMS-MO)

To create a new message in the message editor:

1. Follow the steps in “Getting to Message Features...” to get to *Message Editor*, and then

press  to select.

The message editor displays the contents of the last message entered. If there are no previous messages, the cursor is placed in the upper left corner of the editing area.

2. Press and hold  to clear the entire message editor contents, if necessary.

3. Begin composing your message. **Enter a letter** by pressing a key as many times as necessary.

4. Press  to advance the cursor.

5. Repeat steps 3 and 4 as many times as necessary to complete your message.

6. If message is being sent to an e-mail address, enter e-mail address in beginning of e-mail message and enter in a space followed by message.

Lines of text are automatically formatted in the display. When you reach the bottom of the editing area, the top lines of text scroll up and off the display in order to keep the cursor and the last few lines of text in view. You can enter in up to 160 characters maximum including the e-mail address.

When you have finished composing your message:

7. Press  to access options for that entry.

Message editor menu options let you send the message immediately or store it for later use. These options are described on pages 70-71.

Tip: Press and hold any numeric key to toggle between uppercase and lowercase characters.

Edit a Message (SMS-MO)

You can edit a new message at any time while you are creating it.

You can also edit received messages or messages stored in the outgoing messages list. See “Edit a Stored Message” on page 72 for instructions on how to copy a received message into the message editor. See “Edit a Stored Message” on page 72 for instructions on how to copy an outgoing message into the message editor.

To delete text in a message:

1. Press  to scroll the cursor to the right of the text you want to delete.

2. Press  to delete one character at a time.

Or

Press and hold  to clear the display.

To **add** text to a message:

1. Press  to scroll the cursor to the location where you want to add new text.

2. Enter a letter by pressing a key as many times as necessary.

Edit a Stored Message (SMS-MO)

You can edit a message that you have received, then send the modified message and/or store it in the outgoing messages list.

1. Follow the steps in “Go to the Next Message” on page 73 until you see the message you want to edit, and then press .

2. Press  until you see Edit Message and then press .



The message is copied to the message editor. You will see the final portion of the message displayed in the editing area. The cursor is placed at the end of the message.

For instructions on how to edit a message, see “Message Editor” on page 70.

Send a Message (SMS-MO)

To send a message from the message editor:

1. Press  to access message editor menu options.

2. Press  until you see *Send Message* and then press . You will be prompted to enter the destination address (phone number) for the message.

3. Enter the destination address and then press  to send the message.

Note: Destination number should be entered in standard dialing format. For example, destination is another Iridium phone, destination number is 00 8816 629 00005 or + 8816 629 00005.

If message is being sent to an e-mail address, enter 00*2 or +*2 and press .

The message is sent to your message service center, which forwards the message to its final destination. You will see *Message Sent* when the message arrives at the service center.

If the message cannot be delivered to the service center, you will see *Message Failed*, followed by *Resend?* on the next line. You can:

Press  to resend the message.



Or

Press  to abandon the attempt to send the message at this time. See “Store a Message” on page 63 for instructions on how to store the message for later mailing.

If you have not previously stored a service center number, then you will see *No Service Center*. See “Enter Service Center Number” on page 75 for instructions on how to enter a service center number.







Store a Message (SMS-MO)

To store the contents of the message editor to the outgoing messages list:

1. Press  to access message editor menu options.
2. Press  until you see *Store Message* and then press . You will see *Stored to Outgoing*.

Outgoing messages are stored on your SIM card. When the SIM card is full (indicated by a flashing message indicator), you will not be able to store a message for later retrieval. Use the delete message feature (page 74) to make room for new messages on your SIM card.

Getting to Outgoing Messages...

1. Press  to go directly to the Messages menu.
or
Press  until you see Messages, and then press .
2. Press  to scroll to Outgoing Messages, and then press .
3. Press  to scroll to one of the features described below.

Read a Stored Message (SMS-MO)

This feature displays the first message stored in the outgoing messages list.

To read a stored message in satellite mode:

1. Follow the steps in “Getting to Outgoing Messages...” to enter the message center. You will see the number of messages stored, followed by the first message. If you do not have any messages, you will see *No Messages*.

2. Press  to scroll through the message one screen at a time.

3. Press  to access menu options for the message.





Or

Press and hold  to exit the menu.

Go to the Next Message (SMS-MO)

This feature takes you to the next message in the outgoing messages list.



To go to the next message in satellite mode:

1. **Follow the steps** in “Read a Stored Message” on page 73.
2. **Press**  until you see *Go To Next Message* and then **press** . You will see the next message.
3. **Press**  to scroll through the message one screen at a time.
4. **Repeat steps 2 to 3** to read all of your messages.
5. **Press and hold**  to exit the menu.

Send a Stored Message (SMS-MO)

This feature sends a message stored in the outgoing messages list.

To send a stored message in satellite mode:

1. **Follow the steps in** “Read a Stored Message” on page 73.
2. **Press**  until you see *Send Message* and then **press** . You will be prompted to enter the destination address (phone number) for the message.

3. Enter the destination address and then **press**  to send the message.

The message is sent to your message service center, which forwards the message to its final destination. You will see *Message Sent* when the message arrives at the service center.

If the message cannot be delivered to the service center, you will see *Message Failed*, followed by *Resend?* on the next line. You can:

Press  to resend the message.

Or

Press  to abandon the attempt to send the message at this time.

If you have not previously stored a service center number, then you will see *No Service Center*. See “Enter Service Center Number” on page 75 for instructions on how to enter a service center number.

Edit a Stored Message (SMS-MO)

You can edit a message that you have stored in the outgoing messages list.

To edit a stored message in satellite mode:

1. Follow the steps in “Go to the Next Message” on page 73 until you see the message you want to edit,

and then **press**  .

2. Press  until you see *Edit Message* and then press .

The message is copied to the message editor. You will see the final portion of the message displayed in the editing area. The cursor is placed at the end of the message.



For instructions on how to edit a message, see “Message Editor” on page 70.

Delete a Stored Message (SMS-MO)

Use this feature to make room for new messages on your SIM card.

To delete a stored message in satellite mode:

1. **Follow the steps** in “Go to the Next Message” on page 73 until you see the message you want to delete, and then press .

2. Press  until you see *Delete Message*, and then press . You will see *Message Deleted*.

3. Press and hold  to exit the menu. This feature is not available in cellular mode.

Enter Service Center Number (SMS-MO)

Use this feature to enter the number for the service center that forwards your outgoing messages. You must specify a service number before you can send any messages.

To enter the service center number in satellite mode:

1. **Follow the steps in** “Getting to Message Settings...” to get to *Service Centre*, and then **press**  to select. You will see *Enter Service Number* followed by your current service center number. If this is the first time you have stored a number, continue with **step 3**.







2. **Press**  to clear one digit at a time, **or press and hold**  to erase the entire number.

3. **Enter the new number**, and then **press** . You will see *Completed*.

4. **Press and hold**  to exit the menu.

Tip: The service center number is: 00 8816 629 00005 or + 8816 629 00005.





Getting to Message Settings...

1. Press  to go directly to the Messages menu.
or
Press  until you see *Messages*, and then **press** .
2. Press  to scroll to *Message Settings*, and then **press** .
3. Press  to scroll to one of the features described below.

Set Expiry period (SMS-MO)

This feature specifies the maximum amount of time, in hours, that an unforwarded outgoing message will remain at the service center before it is deleted.

To set the message expiration period in satellite mode:

1. **Follow the steps in “Getting to Message Settings...”** to get to *Expiry Period*, and then **press**  to select. You will see *Enter Hours* followed by the current setting.
2. **Press**  to clear one digit at a time, **or press and hold**  to erase the entire number.
3. **Enter the new number**, and then **press** . You will see *Hours* followed by the number you entered.

4. Press and hold  to exit the menu.

Tip: The default expiration period setting is 192 hours (8 days).

Specify Outgoing Message Type

You can send messages to a device which interprets them in a format other than text. Your service center converts the messages before forwarding them to the destination address.

Note: This feature is not available.

To specify the outgoing message type in satellite mode:

1. Follow the steps in “Getting to Message Settings...” to get to *Outgoing Message Type*, and then

press  to select.

2. Press  to scroll to the desired type (Text is the only available option and is set by default), and then

press  to select it.

3. Press and hold  to exit the menu.

Customizing Phone Features

Once you are comfortable with the basic features of your new phone, use this chapter to set up your phone the way you like it.

What You Will Learn

- adjusting your phone's ringer volume
- choosing from ten different ringer styles
- choosing your phone's keypad tones
- locking and unlocking your phone
- changing and setting codes for security
- resetting or clearing your phone's settings
- selecting the language displayed by your phone



Entering the Phone Setup Menu

To enter the Phone Setup menu:

1. Press  to open the Options menu.

2. Press  to scroll forward.

or

Press  or  to scroll backward or forward.

3. Press  when you see:

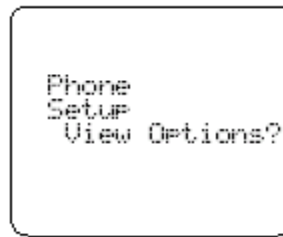

4. Press  to scroll through the submenu.

or

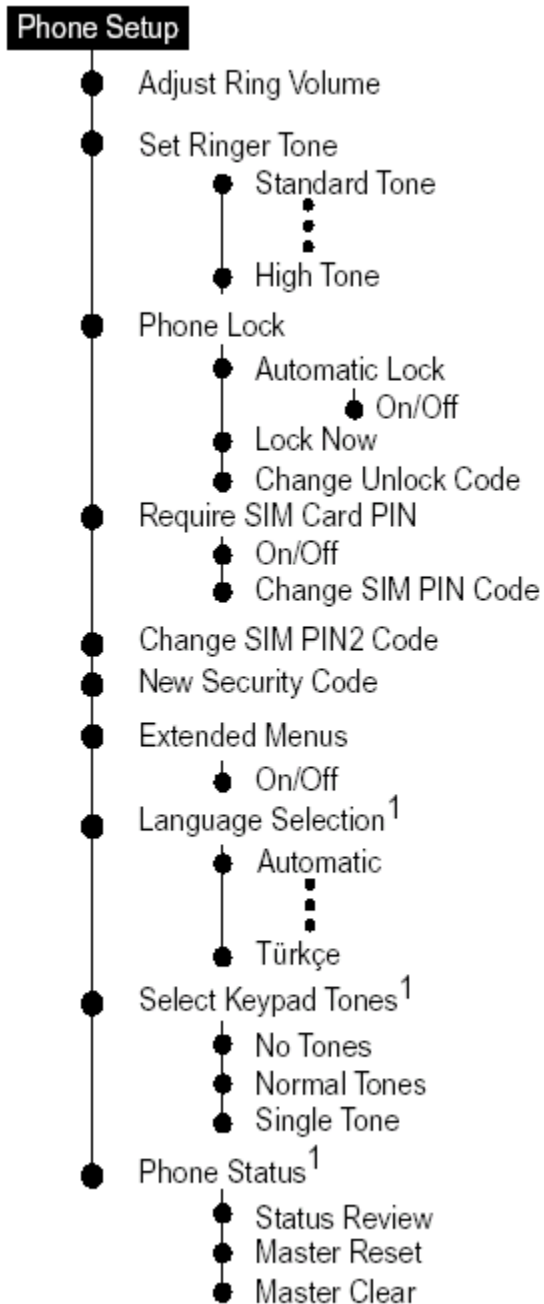

Press  or  to scroll backward or forward through the submenu.

What's on the Phone Setup Menu?



¹ This feature is available only when the extended menu is activated.

Getting to Phone Setup...

1. Press  until you see Phone Setup, and then press .
2. Press  to scroll to one of the features described below. You will see the feature name, followed by Select?.

Adjusting the Ringer Volume

Use this feature to adjust the volume of the ringer. The phone sounds the new volume level as you adjust it.

1. Follow the steps in “Getting to Phone Setup...” to get to Adjust Ring Volume, and then press  to select.

2. Increase the volume by pressing the upper volume key.

or

Decrease the volume by pressing the lower volume key.

3. Press and hold  to exit the menu.

Tip: You can also press , and then the up or down volume key.

Setting the Ringer Tone

Select your favorite tone from 10 different options.

1. **Follow the steps in** “Getting to Phone Setup...” to get to Set Ringer Tone, and then **press**  to select.

2. **Press**  to scroll through the following options:

• Standard Tone • Single Ring Tone

• British Tone • French Tone

• German Tone • Bravo Tone

• Three Ring Tone • Siren Tone



• Quick Tone • High Tone

You will hear a one-ring-cycle demonstration.

3. **Press**  to select the desired option.

4. **Press and hold**  to exit the menu.





Getting to Phone Setup...

1. Press  until you see Phone Setup, and then press .
2. Press  to scroll to one of the features described below. You will see the feature name, followed by Select?.





Setting the Keypad Tones

Choose the sounds your phone makes when its keys are pressed.

Note: This feature is available only when the extended menus are activated. See “Activating Extended Menus” on page 87 for more information.

1. Follow the steps in “Getting to Phone Setup...” to get to Select Keypad Tones, and then press  to select.
2. Press  to choose Normal Tones, Single Tone, or No Tones, and then press .
3. Press and hold  to exit the menu.

Getting to Phone Lock...





1. Press  until you see Phone Setup, and then **press** .
2. Press  until you see Phone Lock, and then **press** .
3. Press  to scroll to one of the features described below.

Locking and Unlocking Your Phone

These features can help you prevent unwanted use of your phone.

Lock the Phone Automatically

Use this feature to set your phone to lock itself every time it is powered on.

1. **Follow the steps in** “Getting to Phone Lock...” **to get to Automatic Lock, and then** **press**  **to select.**
2. **Press**  **to choose On or Off, and then** **press**  **to select. You will see Completed.**
3. **Press and hold**  **to exit the menu.**

Lock the Phone Instantly





Use this feature to lock your phone immediately.

1. Follow the steps in “Getting to Phone Lock...” **to get to Lock Now.**

2. Press  **to select. You will see: Locked.**

Note: Once you unlock your phone, it remains unlocked until you lock it again.

Getting to Phone Lock...

1. Press  until you see Phone Setup, and then press .
2. Press  until you see Phone Lock, and then press .
3. Press  to scroll to one of the features described below.

Unlock the Phone

1. **Enter unlock code.** Enter your four-digit phone unlock code.

2. Press .



Tip: The factory default unlock code is **1234**.

Change the Unlock Code

The unlock code is originally set to **1234**. You should change it as soon as possible.

1. **Follow the steps in** “Getting to Phone Lock...” **to get to Change Unlock Code, and then press**  **to select. You will see Enter Security Code.**

2. Enter security code. Enter your six-digit security code. You will see your current lock code and Enter Phone Unlock Code.





3. Press  to clear one digit at a time, **or press and hold**  to clear all the digits.

4. Enter new code. Enter a new four-digit unlock code, and then **press** . You will see Phone Lock and the new lock code.

5. Press and hold  to exit the menu.

Tip: The factory default security code is **000000**.

Getting to Require SIM Card PIN...

1. Press  until you see Phone Setup, and then press .
2. Press  until you see Require SIM Card PIN, and then press .
3. Press  to scroll to one of the features described below. You will see the feature name, followed by View Options?.



Protecting the SIM Card

You can use a Personal Identification Number (PIN) code to protect the information stored on your SIM card even when it is inserted into someone else's phone.

Activate and Deactivate the SIM Card PIN Code

When you activate the SIM card PIN code, your phone requests the code whenever the phone is powered on. To change this setting, you need to enter the PIN code that your service provider gave you.

1. Follow the steps in "Getting to Require SIM Card PIN...".





2. Press  to scroll to On or Off, and then press . You will see Enter PIN.

3. Enter PIN code. Enter the four- to eight-digit PIN code your service provider gave you, and then **press**

 . You will see Completed.





4. Press and hold  to exit the menu.

Getting to Require SIM Card PIN...

1. Press  until you see Phone Setup, and then **press** .
2. Press  until you see Require SIM Card PIN, and then **press** .
3. Press  to scroll to one of the features described below. You will see the feature name, followed by View Options?.

Change the SIM Card PIN Code

To choose your own PIN code:

1. **Follow the steps in** “Getting to Require SIM Card PIN...” **to get to** Change SIM Card PIN, and then **press**  **to select.** You will see Enter Old PIN.
2. **Enter the current PIN code,** and then **press** . You will see Enter New PIN.
3. **Enter a new PIN code,** and then **press** . You will see Repeat New PIN.
4. **Re-enter the new PIN code,** and then **press**  **again.** You will see Completed.
5. **Press and hold**  **to exit the menu.**

Unblock the PIN Code

If your PIN code is entered incorrectly three times in a row, Blocked appears in the display. You need to enter a PIN unblocking key (PUK1), which you can obtain from your service provider.

1. Press     .



2. **Enter unblocking key.** Enter the eight-digit PUK1 unblocking key, and then **press** . Your service provider supplies this code.

3. **Enter a new PIN code,** and then **press** .

4. **Re-enter the new PIN code,** and then **press** .

Tip: The message Blocked indicates that an incorrect PIN code was entered. The message  Blocked indicates that an incorrect PIN2 code was entered.

Getting to Phone Setup...

1. Press  until you see Phone Setup, and then press .
2. Press  to scroll to one of the features described below. You will see the feature name, followed by Select?.

Managing Other Security Settings

Your phone includes other security features:

- a SIM card PIN2 code for accessing Fixed Dialing settings and other subscription-dependent features
- a security code controls access to security and other menu options

Change the SIM PIN2 Code

Your SIM card PIN2 code is used to access Fixed Dialing settings. This four- to eight-digit code is issued to you when you subscribe to the feature. Use this feature to choose a new code.

1. Follow the steps in “Getting to Phone Setup...” to get to Change SIM Card PIN2 Code, and then

press  to select. You will see Enter Old PIN2.



2. Enter the current PIN2 code, and then press . You will see Enter New PIN2.

3. Enter new PIN2 code, and then press . You will see Repeat New PIN.

4. Re-enter the new PIN2 code, and then press  again. You will see Completed.









5. Press and hold  to exit the menu.

Getting to Phone Setup...

1. Press  until you see Phone Setup, and then press .
2. Press  to scroll to one of the features described below. You will see the feature name, followed by Select?.

Unlock the PIN2 Code





If your PIN2 code is entered incorrectly three times in a row,  Blocked appears in the display. You need to enter a PIN2 unblocking key (PUK2), which you can obtain from your service provider.

1. Press      .
2. Enter unblocking key. Enter the eight-digit PUK2 unblocking key, and then press . Your service provider supplies this code.
3. Enter a new PIN2 code, and then press .
4. Re-enter the new PIN2 code, and then press .

Tip: The message Blocked indicates that an incorrect PIN code was entered. The message  Blocked indicates that an incorrect PIN2 code was entered.





Change the Security Code

The security code is your phone's primary security number. You use it to reset your phone to its default settings and prevent access to your phone book. It is originally set to **000000**.

1. **Follow the steps in "Getting to Phone Setup..."** to get to New Security Code, and then **press**  to select. You will see Enter Security Code.
2. **Enter the current security code**, and then **press** . You will see Enter New Security Code.
3. **Enter a new security code**, then **press** . You will see Security Code and six-digit number selected.
4. **Press and hold**  to exit the menu.

Activating Extended Menus

This feature activates and deactivates the extended menus. See page 97 to learn how extended menus can make your phone even simpler to use.





1. **Follow the steps in "Getting to Phone Setup..."** to get to Extended Menus, then **press**  to select.
2. **Press**  to choose On or Off, and then **press** .
3. **Press and hold**  to exit the menu.





Press and hold  to activate the extended menus temporarily. This shortcut displays all extended menu features until you exit the Options menu.

Selecting the Display Language





Use this feature to select the language in which your phone displays messages.

Note: This feature is available only when the extended menus are activated.

1. **Follow the steps in** “Getting to Phone Setup...” to get to Language Selection, and then **press**  to select.
2. **Press**  to scroll through the choices, and then **press**  to select the displayed option.
3. **Press and hold**  to exit the menu.



If you accidentally change the language of your phone’s display message, press     to return to the language selection menu.

Getting to Phone Status...





1. Press  until you see Phone Setup, and then press .
2. Press  until you see Phone Status, and then press .
3. Press  to scroll to one of the features described below.

Review the Phone's Settings

View all your phone's settings that have changed from their defaults, and reset them to their original settings if you like. Use this feature to review but not change your phone's settings.

1. Follow the steps in "Getting to Phone Status..." to get to Status Review, and then press .
2. Press  to scroll through the list of all the menu items you have changed.
3. Press and hold  to exit the menu.

Getting to Phone Status...

1. Press  until you see Phone Setup, and then press .
2. Press  until you see Phone Status, and then press .
3. Press  to scroll to one of the features described below.

Reset Options to Factory Defaults

Use the master reset option to reset all settings to their original default settings. The master reset option:

- resets audible call timers, the in-call timer, and the automatic lock
- resets extended menus to default setting
- restores keypad tones to normal, ringer tone to standard, and the volume level to the middle (fourth bar) of its range

To reset all settings:

1. Follow the steps in “Getting to Phone Status...” to get to Master Reset, and then press  to select. You will see Enter Security Code.

2. Enter your six-digit security code. You will see Reset Complete.

3. Press and hold  to exit the menu.

Tip: The factory default security code is **000000**.

Clear All Stored Information

The Master Clear option resets the same items as Master Reset, plus the following:

- clear phone book entries from phone memory (not from SIM memory)
- clear last calls made list
- reset resettable call timers

Master Clear does not clear the:

- fixed dial list
- my number(s) list
- received messages list

To clear the settings:

1. Follow the steps in “Getting to Phone Status...” to get to Master Clear, and then **press**  to select. You will see Enter Security Code.

2. Enter your six-digit security code. You will see Reset Complete.

3. Press and hold  to exit the menu.

Tip: The factory default security code is **000000**.

Accessing the Network

This section shows you how to register with the Iridium® satellite network.



Entering the Network Selection Menu

To enter the Network Selection menu:

1. Press  to open the Options menu.

2. Press  to scroll forward.

or

Press  or  to scroll backward or forward.

3. Press  when you see:

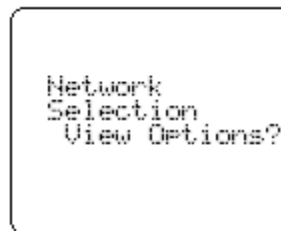

4. Press  to scroll through the submenu.

or



Press  or  to scroll backward or forward through the submenu.

What's on the Network Selection Menu?

Network Selection

 Register Now

Getting to Network Selection...

1. Press  until you see Network Selection, and then press .
2. Press  to scroll to one of the features described below. You will see the feature name, followed by Select?.

Registering With the Satellite Network

Your phone searches for the Iridium satellite network.

1. Follow the steps in “Getting to Network Selection...” to get to Register Now.

2. Press  to select. You will see Registering.... This may take a few seconds.



If the phone finds the signal, you will see Registered and the signal strength indicator:

The  (home system) indicator also appears.

If the phone is unsuccessful you may see one of these messages: System Busy, Restricted Area, or Weak Signal.

Note: You must wait three minutes between registration attempts.

Timing Your Calls

Your phone's call meters give you a variety of options for tracking the time you spend on the phone. You can monitor the length of individual calls, set a timer to track monthly usage, or have the phone alert you with tones at specific intervals.

What You Will Learn

- viewing your phone's call timers to monitor your airtime
- setting your phone's audible alerts to sound at intervals you specify
- activating an in-call display of the elapsed time of your current call
- checking the total airtime of your phone since it was manufactured



Entering the Call Meters Menu

To enter the Call Meters menu:

1. Press  to open the Options menu.

2. Press  to scroll forward.

or

Press  or  to scroll backward or forward.

3. Press  when you see:

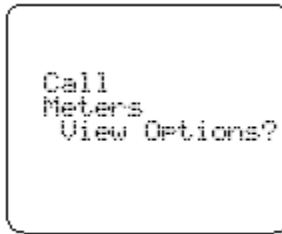

4. Press  to scroll through the submenu.

or

Press  or  to scroll backward or forward through the submenu.

What's on the Call Meters Menu?

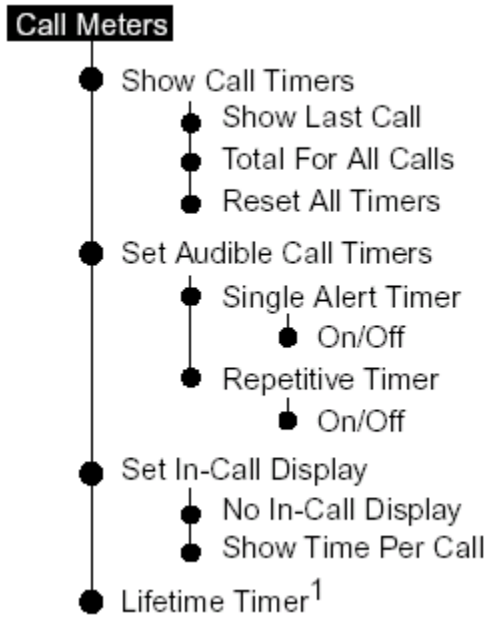

1 This feature is available when the extended menu is active.

Getting to Show Call Timers...

1. Press **MENU** until you see Call Meters, and then **press OK**.
2. Press **MENU** until you see Show Call Timers, and then **press OK**.
3. Press **MENU** to scroll to one of the features described below.

Showing Call Timers

This submenu helps you track your airtime. Keep a running tab of your monthly usage or view the airtime of your most recent call.

Show the Time of the Last Call

Use this feature to display the elapsed time of your most recent call.

1. **Follow the steps in** “Getting to Show Call Timers...” **to get to Show Last Call, and then press OK to select.** You will see the airtime of the most recent call in hours, minutes, and seconds. After several seconds, the display returns to Show Last Call.
2. **Press and hold C** to exit the menu.

Show Total Time for All Calls

Use this feature to display your total airtime since you last reset the Call Timer.

1. Follow the steps in “Getting to Show Call Timers...” to get to Total For All Calls, and then **press**  to select. You will see the airtime accumulated since the timer was last reset. The airtime is displayed in hours, minutes, and seconds. After several seconds, the display returns to Total For All Calls.

2. Press and hold  to exit the menu.

Reset All Timers





Reset your timers at the beginning of each billing cycle to keep track of your spending.

1. Follow the steps in “Getting to Show Call Timers...” to get to Reset All Timers, and then **press**  to select. You will see Completed. The display then returns to Reset All Timers.

2. Press and hold  to exit the menu.

Note: This does not reset the Lifetime Timer described on page 96.

Getting to Audible Call Timers...

1. Press  until you see Call Meters, and then press .
2. Press  until you see Set Audible Call Timers, and then press .
3. Press  to scroll to one of the features described below.

Setting Audible Call Timers



Let your phone watch the clock for you. The call timers signal at a set time or interval with beeps only you can hear.

Set the Single Alert Timer

Use this feature to set your phone to alert you after an elapsed time.

1. Follow the steps in “Getting to Audible Call Timers...” to get to Single Alert Timer, and then press

 to select.

2. Press  to scroll to On or Off, and then press  to select.

- If you select On, you will see Enter Seconds. Continue with **step 3**.

- If you select Off, you will see Completed. Continue with **step 4**.

3. Press  to accept the current setting. You will see Seconds XXX.

or



Enter a number from 11 to 999, and then press . You will see Seconds XXX.

4. Press and hold  to exit the menu.

Set the Repetitive Timer

Use this feature to set your phone to alert you at specific intervals, for example every 45 seconds.

1. Follow the steps in “Getting to Audible Call Timers...” to get to Repetitive Timer, and then press  to select.

2. Press  to scroll to On or Off, then press  to select.

- If you select On, you will see Enter Seconds. Continue with **step 3**.

- If you select Off, you will see Completed. Continue with **step 4**.



3. Press  to accept the current setting. You will see Seconds XXX.

or

Enter a number from 11 to 999, and then **press** . You will see Seconds XXX.





4. Press and hold  to exit the menu.

Getting to Call Meters...

1. Press  until you see Call Meters, and then press .
2. Press  to scroll to one of the features described below.

Showing the In-Call Timer

Use this feature to display a running clock of the airtime elapsed while on a call.

1. Follow the steps in “Getting to Call Meters...” to get to Set In-Call Display, and then press  to select.
2. Press  to scroll to Show Time Per Call or No In-Call Display, and then press  to select.
3. Press and hold  to exit the menu.

Showing the Lifetime Timer

Use this feature to show the total time of all calls for the life of your phone.

Note: This feature is available only when the extended menus are activated. See “Activating Extended Menus” on page 78 for more information.

1. Follow the steps in “Getting to Call Meters...” to get to Lifetime Timer, and then press  to select.

You will see the total airtime of your phone since it was manufactured.

2. Press and hold  to exit the menu.

Tip: The lifetime timer cannot be reset. The Reset All Timers feature has no effect on this timer.

Customizing the Menu System

Do you think your ComCenter has too many features for everyday use? You can do something about it by hiding the features you don't always need. Is your favorite feature not on the Quick Access menu? It's easy to change the defaults to your favorite features. By customizing your menus, your favorite features are always quick and easy to find! This chapter shows you how.

What You Will Learn

- personalizing the Options menu

- personalizing the Quick Access menu

Personalizing the Options Menu







You can customize the Options menu by moving features in and out of the extended menu.

Move Menu Features

To move menu features:

1. **Find the feature** you want to move.







2. **Press and hold**  . You will see one of two responses depending on where that menu feature is currently located. If you see:

| | |
|--|---|
| <p>Remove From Short Menu (the feature is in the short menu)</p> | <p>Press  to move the feature to the extended menu. You will see Menu Item Moved.</p> <p style="text-align: center;">or</p> <p>Press  to scroll to Leave in Short Menus, and then press  to select. You will see Move Cancelled.</p> |
| <p>Add To Short Menu (the feature is in the extended menu)</p> | <p>Press  to move the feature to the short menu. You will see Menu Item Moved.</p> <p style="text-align: center;">Or</p> <p>Press  to scroll to Leave in Long Menus, and then press  to select. You will see Move Cancelled.</p> |

Note: Some features and submenus cannot be moved. You will see Cannot Move Menu Item.

Activate/Deactivate Extended Menus

Use the Options menu to activate and deactivate extended menus. Activate them when you need access to every feature. Deactivate them for everyday use.

1. Press  until you see Phone Setup, and then press  to select.
2. Press  until you see Extended Menus, and then press  to select.
3. Press  to scroll to either On or Off, and then press  to select.

All hidden features are accessible when you activate the extended menus.

Access Hidden Features





If you want to access a feature hidden in the extended menus, but don't want to leave the extended menus active, you can use this shortcut:

Press and hold  for a few seconds.





All extended menus features remain accessible until you exit the Options menu.

Personalizing the Quick Access Menu

You can replace the default Quick Access menu features described on page 34 with any of the following features.

| Icon | Quick Access Feature |
|---|--|
|  | Find by Location recalls Phone Book entries by memory location numbers. |
|  | Add Entry to Phone stores entered numbers in the next available phone memory location. |
|  | Add Entry to SIM stores entered numbers in the next available SIM card location. |
|  | Switch Memory switches One-Touch dialing between the phone and SIM memories depending on the current setting. |
|  | Last Call Timer displays the duration of your last call. |

To change a default quick access feature to one of the features listed above, you must choose the feature you want to replace and then choose the replacement.

1. Press  and then press  to scroll to the feature you wish to change.
2. Press and hold  to access the list of features available.
3. Press  to scroll through the list until you find the desired feature.
4. Press  to store the displayed feature in the new location.

You will see Completed.

Menu Quick Reference

This section provides a quick reference guide to menu structures and features.

Phone Book Menu

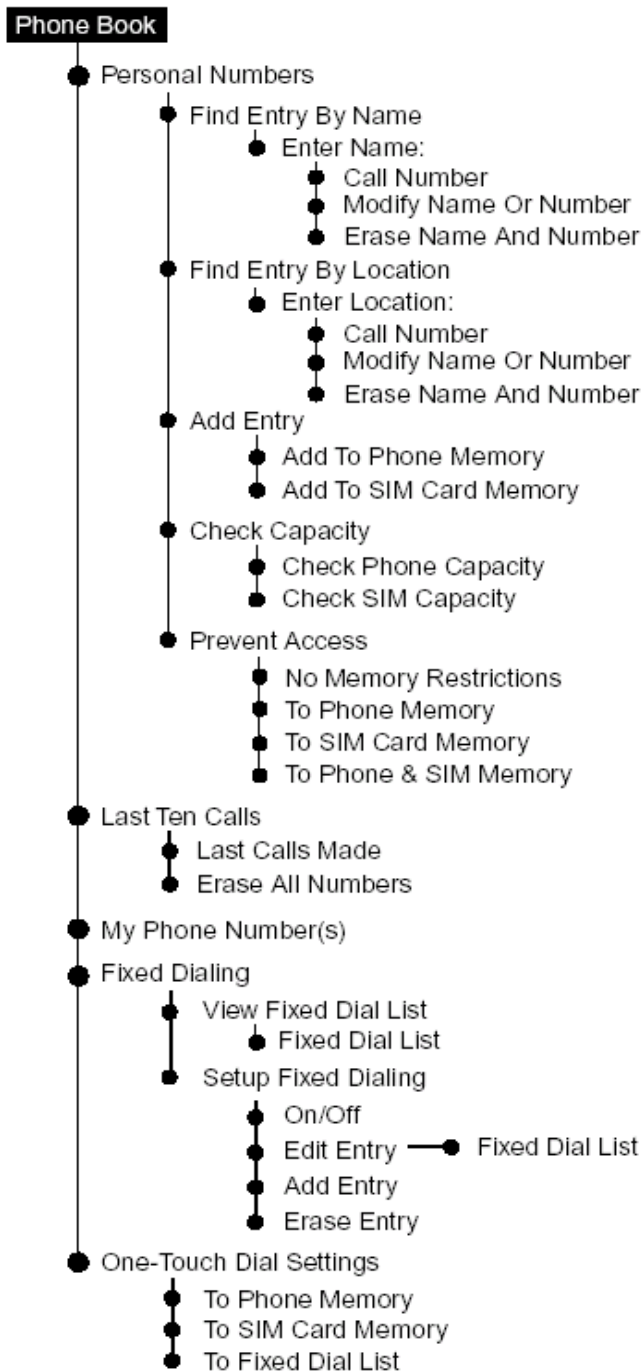

Call Related Features Menu

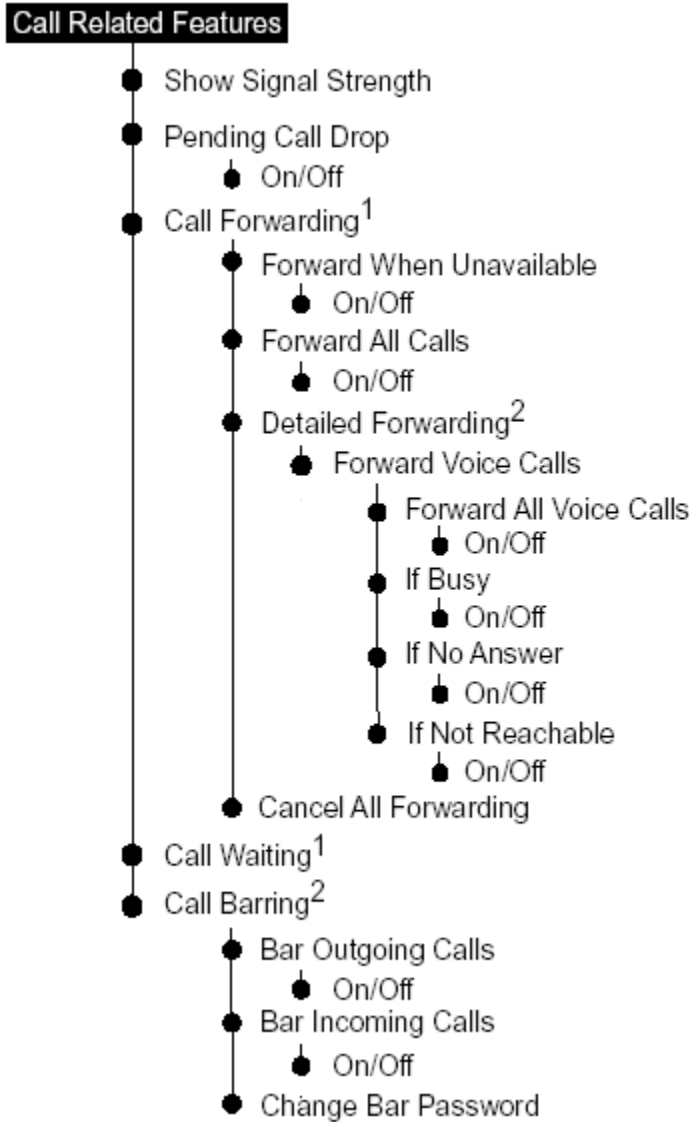

1 This feature is network and subscription dependent.

2 This feature is network and subscription dependent. It is available only when the extended menu is activated.

Messages Menu



Phone Setup Menu

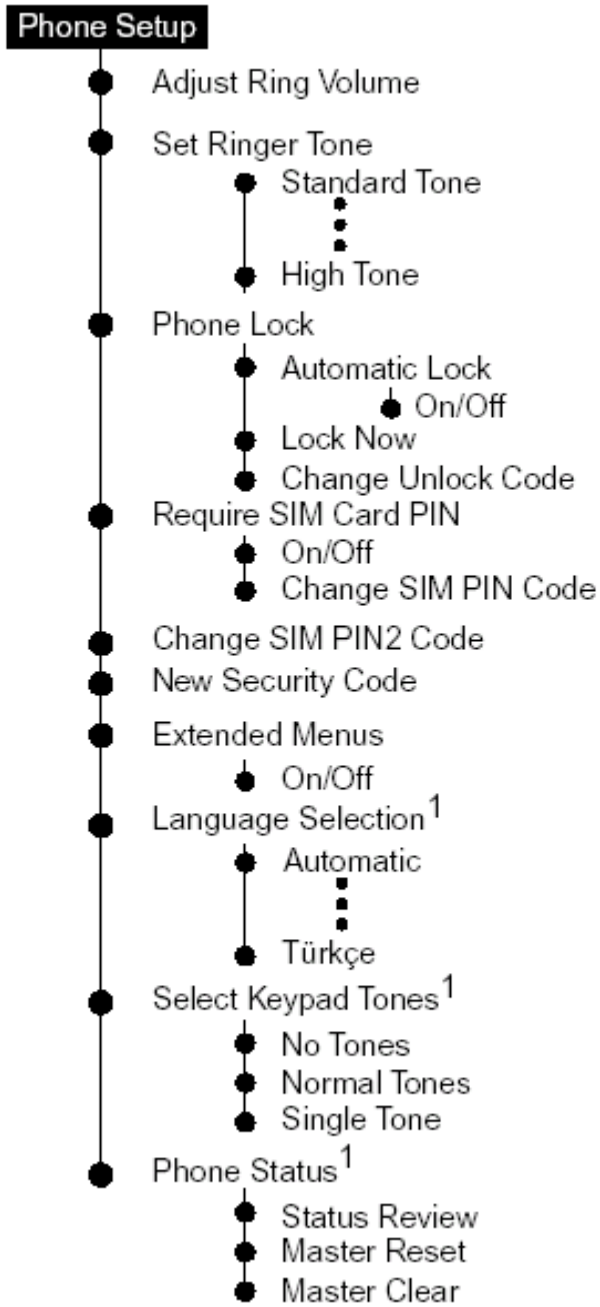

¹ This feature is available only when the extended menu is activated.

Network Selection Menu

Network Selection

● Register Now

Call Meters Menu

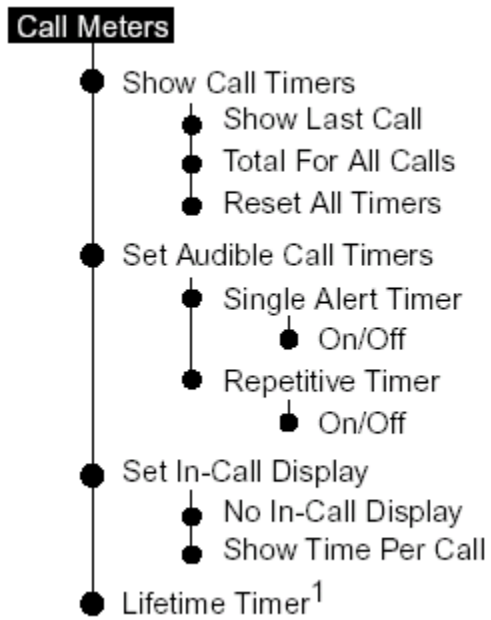





¹ This feature is available only when the extended menu is activated.







Troubleshooting

This chapter tells you what to do if you experience one of the following problems:

| <i>Problem</i> | <i>Solution</i> |
|---|---|
| <p><i>You can't make calls.</i></p> | <ul style="list-style-type: none"> • Check that the antenna is properly mounted. Do you have a clear view of the sky? • Did you enter the number in international format? All calls made from the Iridium satellite system must be in international format. • Check the signal strength meter. If the signal is weak, move the vehicle to a more open area. • Check the Network Selection settings. • Check your Operator coverage map. • Is Restricted displayed? Check the Call Barring setting. • Has a new SIM card been inserted? Check that no new restrictions have been imposed. |
| <p><i>You can't receive calls.</i></p> | <ul style="list-style-type: none"> • Check to see that your phone is powered on. • Check the antenna. Is it properly mounted? Do you have a clear view of the sky? • Check the signal strength. If the signal is weak, move the vehicle |

| | |
|--|--|
| | <p>to a more open area.</p> <ul style="list-style-type: none"> • Check the Call Forwarding and Call Barring settings. • Check the Ringer setting. If it is off, there is no audible ringer |
| <p><i>You can't make International calls.</i></p> | <p>Have you included the relevant codes? Press and hold the  key to display the international dialing prefix (+) and then enter the appropriate country code followed by the phone number.</p> |
| <p><i>Your phone will not unlock.</i></p> | <ul style="list-style-type: none"> • Have you inserted a new SIM card? Enter the new PIN code. • Do you have a replacement phone? Enter the default phone unlock code —1234. • Have you forgotten the unlock code? Press  to change the unlock code (you need your security code). |
| <p><i>Your PIN is blocked.</i></p> | <p>Enter the PIN unblocking key (PUK1) or contact your service provider. See “Unblock the PIN Code” on page 84 for additional information.</p> |
| <p><i>Your PIN2 is blocked.</i></p> | <p>Enter the PIN2 unblocking key (PUK2) or contact your service provider. See “Unblock the PIN2 Code” on page 86 for additional information.</p> |

| | |
|---|--|
| <p>Your SIM card will not work.</p> | <ul style="list-style-type: none"> • Is the card inserted the correct way? • Is the gold chip visibly damaged or scratched? Return the card to your service provider. • Check the SIM and phone contacts. If they are dirty, clean them with an antistatic cloth. |
| <p>You can't cancel Call Forwarding or Call Barring.</p> | <p>Wait until you are in an area with good network coverage and try again.</p> |
| <p>The  (message) indicator is flashing.</p> | <p>There is not enough memory available to store another message. Use the Messages menu to delete one or more messages.</p> |
| <p>You find your phone becoming warm during use..</p> | <p>You may notice this during long calls or during charging.</p> <p>The heat is produced by the electronic components within your phone and is quite normal</p> |
| <p>Your SIM card is inserted in the phone but the display says:</p> | <ul style="list-style-type: none"> • Check Card or Insert Card. <p>Check that the SIM card has been inserted correctly. The contacts of the SIM card may be dirty. Turn the phone off, remove the SIM card and rub the gold chip on the card with a clean cloth. Replace the card in the phone.</p> <ul style="list-style-type: none"> • Blocked or  Blocked |

| | |
|--|---|
| | <p>Enter the PIN unblocking key (PUK1) or the PIN2 unblocking key (PUK2) respectively, or contact your service provider. See “Unblock the PIN Code” on page 84 and “Unblock the PIN2 Code” on page 86 for additional information.</p> <ul style="list-style-type: none"> • Bad Card See Supplier. <p>Please contact your service provider.</p> |
| <p><i>You find your phone's prompts in a language other than your own.</i></p> | <p>Press     . This routes you directly to the language selection submenu. Press  until you see your preferred language. Press  to select.</p> |

Appendix II: Basic AT Command Set

(This information courtesy KDE.org.)

| <i>Command</i> | <i>Description</i> | <i>Comments</i> |
|-----------------------|--|---|
| A0 or A | Answer incoming call | |
| A/ | Repeat last command | Don't preface with AT . Enter usually aborts. |
| B0 or B | Call negotiation | V32 Mode/CCITT Answer Seq. |
| B1 | Call negotiation | Bell 212A Answer Seq. |
| B2 | Call negotiation | Verbose/Quiet On Answer |
| D | Dial | <p>Dial the following number and then handshake in originate mode.</p> <p>P Pulse Dial</p> <p>T Touch Tone Dial</p> <p>W Wait for the second dial tone</p> <p>, Pause for the time held in register S8 (usually 2 seconds)</p> <p>; Remain in command mode after dialing.</p> <p>! Flash switch-hook (Hang up for a half second, as in transferring a call.</p> <p>L Dial last number</p> |
| E0 or E | No Echo | Will not echo commands to the computer |
| E1 | Echo | Will echo commands to the computer (so one can see what one types) |
| H0 | Hook Status | On hook - Hang up |
| H1 | Hook status | Off hook - phone picked up |
| I0 or I | Inquiry, Information, or Interrogation | This command is very model specific. I0 usually returns a number or code, while higher numbers often provide much more useful information. |
| L0 or L | Speaker Loudness. Modems | Off or low volume |

| <i>Command</i> | <i>Description</i> | <i>Comments</i> |
|-------------------------------|--|--|
| | with volume control knobs will not have these options. | |
| L1, L2, L3 | Volume control | Low, medium, and high volume, respectively |
| M0 or M | Speaker off | M3 is also common, but different on many brands |
| M1 | | Speaker on until remote carrier detected (i.e. until the other modem is heard) |
| M2 | | Speaker is always on (data sounds are heard after CONNECT) |
| N0 or N | Handshake Speed | Handshake only at speed in S37 |
| N1 | | Handshake at highest speed larger than S37 |
| O0 or O | Return Online | See also X1 as dial tone detection may be active. |
| O1 | | Return Online after an equalizer retrain sequence |
| Q0 or Q1 | Quiet Mode | Off - Displays result codes, user sees command responses (e.g. OK) |
| Q1 | Quiet Mode | On - Result codes are suppressed, user does not see responses. |
| S_n? | | Query the contents of S-register <i>n</i> |
| S_n=<i>r</i> | Store | Store the value of <i>r</i> in S-register <i>n</i> |
| V0 or V | Verbose | Numeric result codes |
| V1 | | English result codes (e.g. CONNECT, BUSY, NO CARRIER etc.) |
| X0 or X | Smartmodem | Hayes Smartmodem 300 compatible result codes |
| X1 | | Usually adds connection speed to basic result codes (e.g. CONNECT 1200) |
| X2 | | Usually adds dial tone detection (preventing blind dial, and sometimes preventing AT0) |
| X3 | | Usually adds busy signal detection |
| X4 | | Usually adds both busy signal and dial tone detection |
| Z0 or Z | Reset | Reset modem to stored configuration. Use Z0, Z1 etc. for |

| <i>Command</i> | <i>Description</i> | <i>Comments</i> |
|----------------|--------------------|--|
| | | multiple profiles. This is the same as &F for factory default on modems without NVRAM (non-volatile memory) |